

SOFTROL

Software & Control for Automation

MicroPulse Dryer

THE MICROPULSE

SOFTROL

DISPLAY

TIME **33:48**

INLET **4528**

OUTLET **1828**

PROGRAM/OPERATION

Waiting For Dryer
To Receive Load!
Press [YES] Key To
Select Dry Code

1	2	3	ENT
4	5	6	↑
7	8	9	↓
YES	0	CLR	NO

FUNCTION/MANUAL CONTROLS

At Dry Position	Blowers On	Main Fan On	Burner Fan On	Rotate CW	Dryer Horiz	Unload Front	Close Door
Function	Pilot ROX	MainFuel On	Recirc Enable	Rotate CCW	Unload Rear	Load Front	Open Door

1100 Northpoint Parkway

Acworth, GA 30102

770.974.2700

www.softrol.com

This Page has been intentionally left blank.

Contents

- 1. Introduction**
- 2. Front Panel Display**
- 3. Start a Formula**
- 4. Setups Defined**
- 5. Loading the Defaults**
- 6. The RAM Vocabs**
- 7. Learning to Program**
- 8. Defining Instructions**
- 9. Password Levels and Access Rights**
- 10. Maintenance Prompts**
- 11. Key Press**
- 12. Override Displays**
- 13. Copying Memory Contents**
- 14. Hardware Overview**
- 15. Error Fault Lists**
- 16. Default Operations and Formulas**
- 17. Schematic**

This Page has been intentionally left blank.

Introduction to the microPulse Dryer Controller

The Softrol MicroPulse Dryer Controller is the most advanced, state-of-the-art dryer controller in the industry. Its software, specifically designed, provides safe and efficient control and easy formula programming. The controller automatically gathers production data to give clear indication of dryer department efficiency. It is also communications ready, making it possible to transfer production data to a PC workstation via PulseNet, our proprietary plant Floor Networking System. Its modular design allows quick troubleshooting procedures and allows for easy expansion by simply adding modules as needed.

The MicroPulse Dryer Controller consists of two units. The main control enclosure houses the microprocessor and provides the points of connection between the controller and the machine(s). It includes all the input and output modules necessary to actuate the machine and to completely control all the machine processes.

The second enclosure is the Front Panel Display (FPD). The FPD is typically mounted on the front of the machine, and the operator uses it to communicate with the controller. Its operation is easy. Once the machine has been loaded, the operator presses the [YES] key and then selects the desired formula. Password protected access allows key personnel to program new formulas and operations.

The MicroPulse Dryer Controller Front Panel is constructed of corrosion-resistant materials. Its operator-friendly interface reduces the learning curve and speeds up the creation and editing of formulas. The programming mode can only be entered via high-level user passwords for security. There are 128 different formulas and 64 operations that can be programmed and referenced by either name or number. The MicroPulse Dryer Controller keeps in its memory information about the loads processed (including date and time stamping of each load), load time, formula executed, formula time, and unload time.

The MicroPulse Dryer Controller has two basic operating states: Normal Operating Mode and Password Protected Mode.

In the Normal Operating Mode, the MicroPulse Controller will execute programmed formulas, control all aspects of machine operation, monitor and record pertinent machine and process information, and monitor all user-defined operation parameters (i.e., Machine Setups).

The Password Protected Mode allows personnel access to one of seven levels of protected menus via a password. These different levels allow specific users to perform a variety of tasks including programming the controller, specifying user-defined Machine Setups, as well as many other advanced control functions.

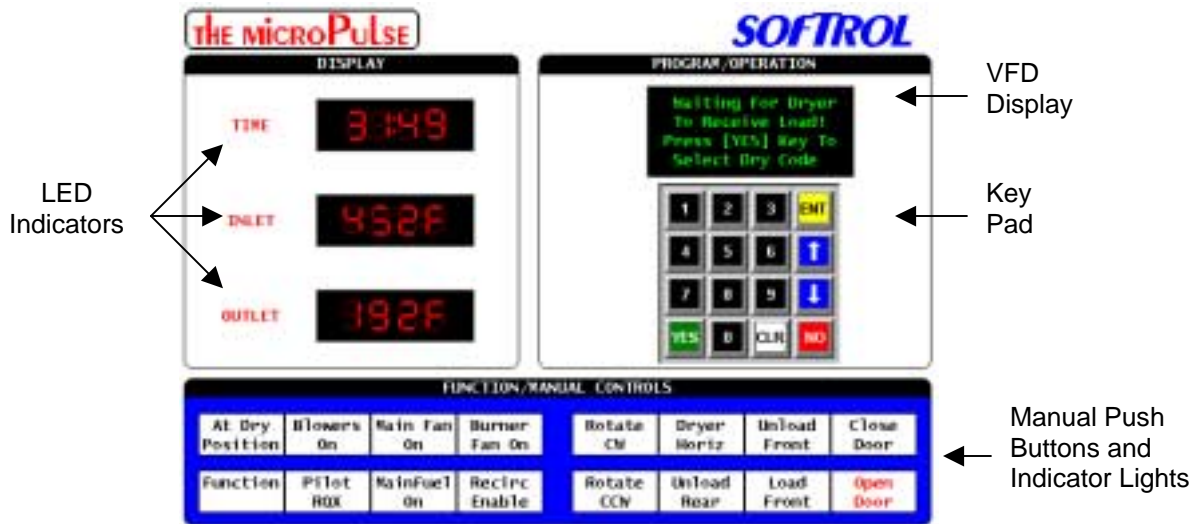

The Front Panel Display (FPD) on the MicroPulse Dryer control has a 4 line by 20-character vacuum florescent display (VFD), 3 light emitting diodes (LED) indicators for time, inlet and outlet temperature displays. 16 key pad for data entry, and 16 pushbuttons for manual operation.

Key Pad Description

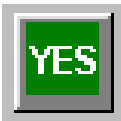

Press the [YES] key to display the formula selection menu. The [YES] key also restarts the formula after it has been paused. In the programming mode, the [YES] key is used to answer setup and programming questions. In the vocabularies mode, the [YES] key moves the cursor left.



The [NO] key pauses the formula. In the vocabularies mode, the [NO] key moves the cursor right.

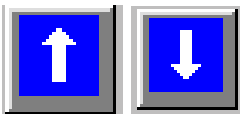

The [UP] and [DOWN] arrow keys are used to scroll while in programming, formula advancement, and a various list of choices.

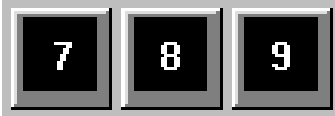

The numerical keys are used to program and setup the machine along with formula starting without the use of scrolling.



The [ENT] key is used to accept choices while in programming, machine setup, and formula starting.



The [CLR] key can be used to pause an operator signal or maintenance alarm for the programmed time in the customer Silent Alarm setups. Pressing the [CLR] key will not silence safety alarms. The [CLR] key is also used in setups and programming to clear the value being programmed setting the value to "0".

Light Emitting Diode (LED) Indicators



The time indicator represents different times depending on the mode of operation.

Formula Execution Mode

During this mode, the time indicator represents in minutes and seconds the time remaining in the formula. This time is the sum of all step times programmed in the formula. The time decreases as the formula proceeds. The time is held while the formula is paused or waiting to satisfy.

Unload Mode

The time display shows the increasing timer while the machine is waiting to be unloaded.

Load Mode

The time display shows the increasing timer while the machine is waiting to be loaded.

Programming Mode

The time displays show the hexadecimal number corresponding to the current menu location. Please note. The Load/Unload time does not increase while in the password protected programming mode.



The Inlet temperature indicates the current temperature of the inlet air supply to the drying chamber. The display will be in either Celsius or Fahrenheit.



The Outlet temperature indicator represents different displays depending on the mode of operation.

Formula Execution Mode

During this mode, the outlet temperature indicator represents the air temperature at the outlet of the drying chamber. The display will be in either Celsius or Fahrenheit.

Programming Mode

The outlet temperature indicator provides information about previous edits performed on the formula or operation. A “0” in the display indicates that the formula or operation has not been edited since it was created. The editing password level is indicated if the formula or operation has been edited.

Manual Pushbuttons and Indicator Lights

At Dry Position	Blowers On	Main Fan On	Burner Fan On	Rotate CW	Dryer Horiz	Unload Front	Close Door
Function	Pilot ROX	MainFuel On	Recirc Enable	Rotate CCW	Unload Rear	Load Front	Open Door

At Dry Position PB 1

This PB has to do with tilt and the light on means the dryer is not tilted but rather horizontal which is the dry tilt position.

Blowers On PB 2

This PB indicates that the blower motors are on. The indicator light illuminates when the blower motors are on.

Main Fan PB 3

This PB indicates that the main fan motor is on. The indicator light illuminates when the main fan motor is on.

Burner Fan PB 4

This PB indicates that the burner fan motor is on. The indicator light illuminates when the burner fan motor is on.

Function PB 5

This PB when in conjunction with other PB's, (Unload Front, Load Front, Open/Close Door) allows manual movement of the machine.

Pilot RQX PB 6

This PB indicates that the controller has requested the Pilot to be lit. The indicator light illuminates when the pilot is being lit.

Main Fuel PB 7

This PB indicates that the main fuel valve is opened. The indicator light illuminates when the main fuel valve is open.

Recirculation Enabled PB 8

This PB on equipped machines indicates that the recirculation flap is closed. The indicator light illuminates when the recirculation flap is opened.

Rotate CW PB 9

This PB rotates the basket forward (clockwise) during loading and unloading. The indicator light illuminates when the basket is rotating in the forward direction.

Dryer Horiz PB 10

On equipped machines, this PB will lower the front/rear of the machine into the run position. The indicator light illuminates while the machine is being placed into the run position

Unload Front PB 11

On equipped machines, this will raise the rear of the machine into the unloading position. The indicator light illuminates when the rear of the machine is in the unload position.

Close Door PB 12

Pressing and holding this PB in conjunction with the function button will close the Dryer's front door. These buttons must be held in until the door is closed. If not, the door will return to the open position. The indicator light illuminates when the door is fully closed and the control sees the door closed switch.

Rotate CCW PB 13

This PB rotates the cylinder reverse (counter clockwise) during loading and unloading. The indicator light illuminates when the cylinder is rotating in the reverse direction.

Unload Rear PB 14

On equipped machines, this will raise the front of the machine into the unloading position. The indicator light illuminates when the front of the machine is in the unload position.

Load Front PB 15

On equipped machines, this will raise the front of the machine into the loading position. The indicator light illuminates when the machine is in the load position

Open Door PB 16

This will open the machines front door. The indicator light illuminates when the door is fully opened.

Notes:

Starting a Formula

To execute a formula you must load the machine, close the door and return to horizontal before running a formula.

Waiting for Dryer
to Receive Load!!
Depress [YES] Key to
Select Formula

Press the [YES] key.

Formula Number 0
Use arrow key to select

ENTER=accept 0=exit

Enter the desired formula number or using the arrow keys, scroll to the desired formula number to be executed. For example to execute formula number 100 press [1][0][0].

Formula # 100
Sheets
Use arrow key to select
ENTER=accept 0=exit

Press [ENT].

Sheets
INITIAL HEAT
Step # 1 Line # 2
T=0:26 S=4:56

After the formula execution, the MicroPulse Dryer controller will start timing how long it takes to unload the machine. The display will read.

Sheets
Waiting for Dryer
To Unload!!
Press [YES] Key Continue

Press the [YES] key.

Sheets
Waiting For Dryer
To Unload!!!
T=25:46 Step =0:00

The display shows the last formula to be executed. Formula number 100: Sheets. The display shows how long the formula ran during that execution. T=25:46.

Resetting the MicroPulse

To be able to execute another formula, the control must be reset to the Waiting to Load display. There are two ways to do this. The first way being opening the rear door and tilting to the unload rear position, and then closing the rear door. The second way to reset the display to the Waiting to Load screen, enter a valid level 1 to 7 password. Now press the [ENT] + [NO] simultaneously to reset the display.

MicroPulse Tilting Machines

To unload a tilting machine, press the [Unload Rear] or [Unload Front] button depending on the unload location. After the machine is fully tilted, the [Unload Rear] or [Unload Front] button depending on the unload location, will remain illuminated.

To rotate the load from the basket, the operator can press and hold the [Function] button and either the [Rotate CW] button or the [Rotate CCW] button depending on the direction preferred.

After the unloading is complete, close the rear door. This resets the display to the Waiting to Load screen.

Advancing in a Formula

To advance in a formula, enter a valid level 1-7 password. Using the [UP] arrow key, scroll forward to the desired step in the formula.

Reversing in a Formula

The MicroPulse Dryer Controller will not allow you to scroll backward in a formula. If the advanced programming functions are not used to control formula flow and you need to go backwards in a formula, you must cancel the formula, restart the formula, then advance to the desired step in the formula.

Canceling a Formula

To cancel a formula, pause the program by pressing the [NO] key. Enter a valid level 1-7 password. Press the [YES] and the [NO] keys simultaneously twice to reset to the "Waiting to Load" display.

Adding and Subtracting Time During Formula Execution

For Safety purposes, the freeze timer (Level 8) is disabled during formula execution although the freeze timer may be used after the formula has completed.

Setup Procedure

The machine setups tailor the operation to suit individual preferences and applications. These parameters are global meaning they affect all formulas. Some of these parameters (maximum temperature, for example) can also be set locally to override the global parameters and only effect the current formula. Local parameters are normally used in special circumstances and are controlled through the Advanced Functions. Please refer to the Advanced Functions for information. Use the following sequence to set up the user programmable features.

From the "Waiting to Receive Load" display, enter a valid level 7 password (please refer to Passwords).

1=Setups 2=Program
3=Maint. 4=Diagnos
5=Totals 6=Clock
Selection? 0=exit

Select 1=Setups

1=Machine Setup
2=Maintenance Setup
3=Clear Ram Vocabs
4=Passwords 0=exit

Select 1=Machine Setup

The current setting is shown on the display. The Programmable Functions section describes all of the questions in detail.

Note: Use the [YES] or [NO] keys and the numbers on the keypad to change the answer to the setup questions. Some questions require the operator to enter a value.

Press the [ENT] key to accept the answer.

Press only the [ENT] key to accept the default or keep the previously programmed value.

You cannot go backwards through the questions. If you need to change the answer to a previous question, press the [ENT] key to accept the current values to the remaining questions then restart the procedure.

Press the [CLR] key to clear the numeric value of the current question. After all setups are complete pressing the [CLR] key will accept the changes. The MicroPulse does not store any of the changes in memory until the last setup

question is answered and the [CLR] key is pressed. If the power is lost during the setup procedure, the changes will not take effect.

Metric System

This indicates whether the user desires the Level and Temperature prompts to be in Inches/Deg F or Millimeters/Deg C. If Metric Selected, prompts in the Setup routine will change to MM and Deg. C where appropriate. Answer YES for Metric or NO for English.

Heat Overtime Error

This time in MM:SS is the longest possible time that is desired for the heat to be on during one formula execution. If the heat is on for a time greater than this set time, formula execution will be halted and the *Heat Overtime Error* will be displayed. This setup is intended to eliminate any conditions that would allow excessive heat cycles.

Inlet Temp Hi

This is the highest temperature limit that the drying chamber inlet will attain. If the inlet temperature reaches this level, formula execution will be halted and the *Inlet Temp Hi* error message will be displayed. This setup is intended to prevent load damage due to high temperature.

Inlet Temp Lo

This is the lowest temperature limit that the drying chamber inlet will attain. If the inlet temperature reaches this level, formula execution will be halted and the *Inlet Temp Lo* error message will be displayed. This setup is a useful tool to help diagnose a bad or faulty RTD.

Outlet Temp Hi

This is the highest temperature limit that the drying chamber outlet will attain. If the outlet temperature reaches this level, formula execution will be halted and the *Outlet Temp Hi* error message will be displayed. This setup is intended to prevent load damage due to high temperature.

Outlet Temp Lo

This is the lowest temperature limit that the drying chamber outlet will attain. If the outlet temperature reaches this level, formula execution will be halted and the *Outlet Temp Lo* error message will be displayed. This setup is a useful tool to help diagnose a bad or faulty RTD.

Main Fan Vacuum Lo

Measured in inches, this is the minimum suction pressure of the Main Fan that will be required for a safe formula execution. If the suction pressure of the Main Fan drops below this setting, formula execution will be halted and the *Main Fan Vacuum Lo* error message will be displayed. This may indicate the lint filter requires cleaning.

Note: Vacuum pressures are not usually installed and that the setups should have certain values if not installed to prevent errors.

Main Fan Vacuum Hi

Measured in inches, this is the maximum suction pressure of the Main Fan that will be required for a safe formula execution. If the suction pressure of the Main Fan exceeds this setting, formula execution will be halted and the *Main Fan Vacuum Hi* error message will be displayed. Default setting 11.00”.

Makeup Air Vacuum Lo

Measured in inches, this is the maximum suction pressure of the Makeup Air Blower that will be required for a safe formula execution. If the suction pressure of the Makeup Air Blower falls below this setting, formula execution will be halted and the *Makeup Air Vacuum Lo* error message will be displayed. Default setting 0.00”.

Makeup Air Vacuum Hi

Measured in inches, this is the maximum suction pressure of the Makeup Air Blower that will be required for a safe formula execution. If the suction pressure of the Makeup Air Blower exceeds this setting, formula execution will be halted and the *Makeup Air Vacuum Hi* error message will be displayed. Default setting 11.00”.

Integral #1 Timer

This setup is referred to as the RESET. The Integral #1 Timer is a value in seconds of how often the Outlet temperature integral is calculated. The initial setting for reset should be the lowest number of resets per minute. Increase the resets per minute in small increments, allowing the system to settle down before making additional changes. When the system starts to oscillate, back the setting off enough to re-establish system equilibrium.

Integral #2 Timer

The Integral #2 Timer is a value in seconds of how often the Inlet temperature integral is calculated. The initial setting for reset should be the lowest number of resets per minute. Increase the resets per minute in small increments, allowing the system to settle down before making additional changes. When the system starts to oscillate, back the setting off enough to re-establish system equilibrium.

Derivative #1 Timer

This is a value in seconds of how often the Outlet temperature derivative is calculated. This is sometimes called Rate. The Rate's function is to reduce or eliminate overshoot. It is based in time, which must be tuned to work with the overall system response time. The initial setting for the rate should be at the highest resets per minute possible. Decreasing the seconds in the setup increases the resets per minute. Increase the resets per minute in small increments. After each adjustment, observe the approach of the actual outlet temperature to the programmed set point. If it overshoots, continue to increase the reset rate in small increments. Continue adjusting the resets per minute, lowering it until the outlet set point is controlled and stable. If at some point the system becomes very sluggish or may not be able to reach the new set point, then too much rate has been adjusted into the control system. The number of resets per minute of rate must be decreased to reduce the "dampening effect".

Derivative #2 Timer

This is a value in seconds of how often the Inlet temperature derivative is calculated. The Rate's function is to reduce or eliminate overshoot. It is based in time, which must be tuned to work with the overall system response time. The initial setting for the rate should be at the highest resets per minute possible. Decreasing the seconds in the setup increases the resets per minute. Increase the resets per minute in small increments. After each adjustment, observe the approach of the actual inlet temperature to the programmed set point. If it overshoots, continue to increase the reset rate in small increments. Continue adjusting the resets per minute, lowering it until the inlet set point is controlled and stable. If at some point the system becomes very sluggish or may not be able to reach the new set point, then too much rate has been adjusted into the control system. The number of resets per minute of rate must be decreased to reduce the "dampening effect".

Outlet Kp

Enter a constant from 1-10 for the Outlet temperature calculations. This value will increase the amount of change of the firing rate motor as it continues to move away from the set point. The value of this constant should be as small as possible to yield stability. Increasing the constant allows more changes in the firing rate.

Inlet Kp

Enter a constant from 1-10 for the Inlet temperature calculations. This value will increase the amount of change of the firing rate motor as it continues to move away from the set point. The value of this constant should be as small as possible to yield stability. Increasing the constant allows more changes in the firing rate.

Gas Meter

This setup tells the controller if there is a gas meter being used to measure the gas flow amount during formula execution.

Type 1

This is a flow meter that uses a 4-20 milliamps communication.

Type 2

This is a flow meter that uses pulsating communications.

K-Factor

If a gas meter is being used, this setting tells the controller the pulses per inch of the gas meter.

Prompt Weight

This indicates whether the operator wishes to prompt the weight of the load before the start of each formula.

Low Weight Allowed - If Prompt Weight is answered Yes, enter the Low Weight Value of valid weight range for the machine.

High Weight Allowed - If Prompt Weight is answered Yes, enter the High Weight Value of valid weight range for the machine.

ArcNet Node

This allows the user to define if the machine is in an automated system or a manual system. This must be answered Yes in all automatic systems.

Full Baud Rate

Y/N this is used only when a RS 232 port network is active on the Arcfiber card.

Multidrop Net

Y/N this is used only when a RS 232 port network is active on the Arcfiber card.

LAN Member ID #

This is used only when a RS 232 port network is active on the Arcfiber card.

NOTE: THESE SETUPS ARE ONLY IF ARCNET NODE= YES.

Loading Position

This is the position for a shuttle to load the dryer. Positions are numbered in a system from 0 to 32. Position 0 is always to the far left of the wash aisle facing the dryer. The rightmost position is determined for each system and is the last needed position to the far right of the wash aisle facing the dryer aisle from the washer's aspect.

Unloading Position

This is the position for a shuttle or a conveyor to unload the dryer. The unloading position setup follows the same rules as the loading position for shuttle unloaded machines.

Machine Class Type

This is the class type of the machine. The valid range is 0 to 94. Certain machines may be equipped differently than other machines. In addition, certain processes may be preferred in particular machines. This is accomplished through using the Class Type. When items to be processed are entered into the AutoPulse system, they are assigned a Class Type Number for the Dry Classification. The corresponding items will be processed in a machine with a matching Class Number. Assigning Machine Class Type 99 will prevent the machine from automatic operation and is useful when maintenance or testing is performed on a machine.

Sequence Priority #

The sequence priority establishes the manner in which machines are selected for loading and unloading. Machines with a sequence priority of zero will rotate priority according to how long the machines have been waiting to load or unload. Machines with a sequence priority greater than zero attain a higher priority of selection than those units with a sequence priority of zero. A sequence Priority of 1 is the highest priority. The available machine with the smallest non-zero priority will be selected preferentially. Machines with the same priority will be handled in a shortest path algorithm, meaning that the machine closest to the current position of the shuttle will be handled first.

Minimum Weight

This establishes the minimum weight that a machine will accept for a load.

Maximum Weight

This establishes the maximum weight that a machine will accept for a load.

Lo Formula Range 1-3

This establishes the minimum formula number for a formula range 1-3 that a machine will accept for a load. Three acceptable ranges can be established.

Hi Formula Range 1-3

This establishes the maximum formula number for formula range 1-3 that a machine will accept for a load.

Belt System

This setup determines whether the dryer will be unloading onto a shared flat belt conveyor (East/West type) and/or a shuttle belt system. If the dryer is to unload automatically onto a flat belt conveyor, answer YES. When unloading onto a flat belt conveyor, unloading position indicates which direction to run the belt when

unloading the dryer. If the dryer is to unload automatically onto a scissors shuttle, answer YES.

Send Data Record

This setup works in conjunction with the optional database (GUPPI) program. Answering (Yes) sends the data record to a printer console or to a CSV file connected to the database.

Idle At Load Position

This setup determines whether the dryer will be positioned at the horizontal rest position with doors closed or the accept load position when waiting for a load from the shuttle. In some climates, it is preferable to have the dryer waiting in the horizontal door closed position to prevent cold and/or hot air from entering into climate-controlled environments. If the dryer is to sequence to the Load Position At Idle, answer YES. Otherwise, answer NO.

Loading Height

This establishes the height that a scissors shuttle should be positioned at to load the machine. A height of 0 is the lowest height and a height of 99 is the highest height. If the system does not utilize a scissors shuttle, this setup may be programmed to 0.

Loading Depth

This establishes the depth that a scissors shuttle should be positioned at to load the machine. A depth of 0 is the depth of the shuttle when positioned at the shuttle's southern limit. Depth may increase to a maximum of 99. Depth's greater than the shuttle's middle limit establish positioning towards the shuttle's northern limit. If the system does not utilize a scissors shuttle, this setup may be programmed to 0.

Unloading Height

This establishes the height that a scissors shuttle should be positioned at to load the machine. A height of 0 is the lowest height and a height of 99 is the highest height. If the system does not utilize a scissors shuttle, this setup may be programmed to 0.

Unloading Depth

This establishes the depth that a scissors shuttle should be positioned at to unload the machine. A depth of 0 is the depth of the shuttle when positioned at the shuttle's southern limit. Depth may increase to maximum of 99. Depth's greater than the shuttle's middle limit establish positioning towards the shuttle's northern limit. If the system does not utilize a scissors shuttle, this setup may be programmed to 0.

Loading the Defaults

Default Operations

From the Waiting to Load screen, enter a valid level 6 or 7 password.

1=Setups 2=Program
3=Maint. 4=Diagnos
5=Totals 6=Clock
Selection? 0=exit

Select 2=Program

1=Ops2=Formulas
3=Clr Ops 4=Clr Forms
5=Copy 6=Prompts
Selection? 0=exit

Select 3=Clr Ops

Load Defaults
Use YES/NO Keys
ENTER=accept 0=exit

Select YES then press [ENT]. This loads all default operations for quick reference.

Default Formulas

1=Ops2=Formulas
3=Clr Ops 4=Clr Forms
5=Copy 6=Prompts
Selection? 0=exit

Select 4=Clr Forms

Load Defaults
Use YES/NO Keys
ENTER=accept 0=exit

Select YES then press [ENT]. This loads all default formulas for quick reference.

Exit out of the control. From the Waiting to Load screen, enter a valid level 7 password.

Default Vocabs

1=Setups 2=Program
3=Maint. 4=Diagnos
5=Totals 6=Clock
Selection? 0=exit

Select 1=Setups

1=Machine Setup
2=Maintenance Setup
3=Clear Ram Vocabs
4=Passwords 0=exit

Select 3=Clear Ram Vocabs

Clear All Ram Vocabs

Key in Password!!!!
NO=exit

Enter a valid level 7 password and all Ram Vocabs are cleared loading all default vocabs. Exit out of the control.

RAM Based Vocabularies

RAM based vocabularies are user-programmable “words” that are used on the MicroPulse Dryer Controller to display information and operator prompts. The user may edit the following vocabularies.

- | | | | |
|----|-------------------|-----------|---------------|
| 1. | Formula Names | 128 Words | 16 Characters |
| 2. | Operation Names | 32 Words | 16 Characters |
| 3. | Formula Prompts | 32 Words | 16 Characters |
| 4. | Maintenance Items | 32 Words | 16 Characters |

To enter the RAM based vocabularies on the MicroPulse Dryer Controller; you use a universal word editor. This word editor uses the same commands to enter and edit all vocabulary words. The desired word is entered from the keypad and then it must be saved. Each individual character in the word is entered using its ASCII code number. For example, to enter an “A” press [065] on the FPD, which is the ASCII code number for “A”.

The ASCII Character Codes

The ASCII Character Codes are used to enter text into the programmable text (RAM Vocab). The RAM Vocab is used to enter maintenance prompts, text prompts, operation names, and formula names. Refer to the appropriate section in the MicroPulse Dryer manual for detailed instructions on entering the character codes.

032 = (space)	052 = 4	071 = G	090 = Z	109 = m
033 = !	053 = 5	072 = H	091 = [110 = n
034 = "	054 = 6	073 = I	092 = ¥	111 = o
035 = #	055 = 7	074 = J	093 =]	112 = p
036 = \$	056 = 8	075 = K	094 = ^	113 = q
037 = %	057 = 9	076 = L	095 = _	114 = r
038 = &	058 = :	077 = M	096 = `	115 = s
039 = '	059 = ;	078 = N	097 = a	116 = t
040 = (060 = <	079 = O	098 = b	117 = u
041 =)	061 = =	080 = P	099 = c	118 = v
042 = *	062 = >	081 = Q	100 = d	119 = w
043 = +	063 = ?	082 = R	101 = e	120 = x
044 = ,	064 = @	083 = S	102 = f	121 = y
045 = -	065 = A	084 = T	103 = g	122 = z
046 = .	066 = B	085 = U	104 = h	123 = {
047 = /	067 = C	086 = V	105 = I	124 =
048 = 0	068 = D	087 = W	106 = j	125 = }
049 = 1	069 = E	088 = X	107 = k	126 =
050 = 2	070 = F	089 = Y	108 = l	127 =
051 = 3				

Programming The Prompts

The Prompt instruction is a very useful instruction that can be found in the Advanced Functions in the instruction list of the MicroPulse Dryer control. It allows the user to supply information the operator. Up to three prompts may be displayed at once. One or Two prompt instructions may be combined to provide additional information to the operator. Following is an example of how this Advanced Function is used.

005: Tumble Only
006: Dwell Timer 999 Seconds
007: Prompt: Check Load!!
008: Prompt: Is Load Dry?
009: Signal Until Operator Cancels

Editing User Defined Prompts

To program the user defined prompts, from the Waiting to Load screen, enter a valid level 6 or 7 password.

1=Setups 2=Program
3=Maint. 4=Diagnos
5=Totals 6=Clock
Selection? 0=exit

Select 2=Program

1=Ops2=Formulas
3=Clr Ops 4=Clr Forms
5=Copy 6=Prompts
Selection? 0=exit

Select 6=Prompts

Line 2 on the LCD will display the current text.

Prompt # 1
Prompt # 1
Use arrows to scroll
ENTER=accept NO=exit

Scroll to the desired prompt and press [ENT]
Prompt # 27
ENT= Character # 10
YES = Left NO = Right
YES + NO = Accept

The cursor (appears as a flashing line) the character position to be edited. With the cursor in position, key in the numerical code (see the ASCII reference) for the desired character. For example if you are programming Unload Dryer. Press [8][5] then press [ENT]. The U will be shown now press the [NO] key to move the cursor right.

Urompt # 27

ENT= Character # 85

YES = Left NO = Right

YES + NO = Accept

Continue with this sequence until you have programmed the desired operation name.

U=[8][5] [ENT] [NO]
n=[1][1][0] [ENT] [NO]
l=[1][0][8] [ENT] [NO]
o=[1][1][1] [ENT] [NO]
a=[9][7] [ENT] [NO]
d=[1][0][0] [ENT] [NO]
space=[3][2] [ENT] [NO]
D=[6][8] [ENT] [NO]
r=[1][1][4] [ENT] [NO]
y=[1][2][1] [ENT] [NO]
e=[1][0][1] [ENT] [NO]
r=[1][1][4] [ENT] [NO]
space=[3][2] [ENT] [NO]
space=[3][2] [ENT] [NO]
space=[3][2] [ENT] [NO]
space=[3][2] [ENT] [NO]
[YES]+[NO]

1=Ops2=Formulas

3=Clr Ops 4=Clr Forms

5=Copy 6=Prompts

Selection? 0=exit

If required, repeat the procedure or exit.

Learning to Program the MicroPulse Dryer Controller

The normal programming sequence is:

- Load default operations, formulas, and vocabs into the control.
- Program your User Defined Setups.
- Program user defined prompts.
- Program operations.
- Program formulas.
- Setup passwords.
- Edit preventative maintenance prompts and next service intervals.

Formula Planning

Inserting lines of instructions and operations create formulas. To aid in this, with the MicroPulse Dryer controller you can build operations and inset them into formulas. Inserting lines of instructions creates operations.

In planning for programming operations, it is necessary to view your formulas and see which instructions are most used. After determining this, build a set of operations that most fit your drying needs. The MicroPulse Dryer controller has default operations ranging from operation numbers 33 to 64. These are for the user to use to learn to program by or even to use in their formulations. The MicroPulse Dryer controller also has default formulas ranging from formulas 100 to 128. These are a good for referencing. Examples of each may be found later in the manual.

Formula Name

Formula Name is always the first instruction of any formula. The formula name may not be deleted. Editing the formula name enables the corresponding formula for selection by the operator. Setting the Formula Name to Unused prevents selection of the formula by the operators.

Formula End

Formula End is always the last instruction of any formula. Inserting instructions and operations between the Formula Name and the Formula End instructions creates formulas. Memory usage is dynamic so that formulas take up only the required amount of memory.

Operation Name

Operations are programmed just like formulas. An operation is usually a commonly used set of instructions to carry out a desire sequence like INITIAL HEAT. Operations may be inserted into formulas like MACROS, and then edited to suit the exact need of the formula. When editing operations, the OPERATION NAME is always the first instruction of any operation. Editing the OPERATION NAME enables the corresponding operation for insertion in formulas.

Operation End

Operation End is always the last instruction of and operation. Inserting instructions between the OPERATION NAME and the OPERATION END instructions creates operations. Memory usage is dynamic so that operations take up only the required amount of memory. OPERATION END is not copied into a formula when an operation is inserted.

Programming Operations

Since formulas are easier to program with operations, operations need to be programmed first. Setting up operations will save substantial time later when formulas are programmed.

Name the Operation

From the Waiting to Load screen, enter a valid level 6 or 7 password.

1=Setups 2=Program
3=Maint. 4=Diagnos
5=Copy 6=Clock
Selection? 0=exit

Select 2=Program

1=Ops2=Formulas
3=Clr Ops 4=Clr Forms
5=Copy 6=Prompts
Selection? 0=exit

Select 1=Ops

Key in Oper. # 0

ENTER= Accept NO = Exit

Scroll or enter the number that you wish to program and press [ENT].

1:001 ?OPERATION?
002 END OPERATION

3-e 5-s 0-exit

The first line is the active line and all editing operates on the contents of that line. Line 4 on the LCD lists the editing options that are possible. 3-e is for editing the top line. 5-s scrolls the LCD screen left and right. Only 20 characters may display on a line and this option allows more of the line to be viewed. Press [3] to edit.

Operation # 1
CLR= Set to Unused
ENT= Edit Name
0 = exit

Press the [CLR] key to set too unused. Press the [ENT] key to edit the operation name.

ENT= Character # 00
YES = Left NO = Right
YES + NO = Accept

The cursor (appears as a flashing line) the character position to be edited. With the cursor in position, key in the numerical code (see the ASCII reference) for the desired character. For example if you are programming COOLDOWN. Press [6][7] then press [ENT]. The C will be shown now press the [NO] key to move the cursor right.

C_
ENT= Character # 67
YES = Left NO = Right
YES + NO = Accept

Continue with this sequence until you have programmed the desired operation name.

C=[6][7] [ENT] [NO]
O=[7][9] [ENT] [NO]
O=[7][9] [ENT] [NO]
L=[7][6] [ENT] [NO]
D=[6][8] [ENT] [NO]
O=[7][9] [ENT] [NO]
W=[8][7] [ENT] [NO]
N=[7][8] [ENT] [NO]
space=[3][2] [ENT] [NO]
space=[3][2] [ENT] [NO]
space=[3][2] [ENT] [NO]
space=[3][2] [ENT] [NO]
space=[3][2] [ENT] [NO]
space=[3][2] [ENT] [NO]
space=[3][2] [ENT] [NO]

space=[3][2] [ENT] [NO]
[YES]+[NO]

1:001 COOLDOWN
002 END OPERATION

3-e 5-s 0-exit

Now using the arrow keys, place the active line to the top line.

002 END OPERATION

1-i 2-d 3-e 5-s 0-exit

Line 4 on the LCD list the editing options that are possible. 1-i insert. 2-d delete. 3-e edit. 5-s shift. 0-exit. Press 1-i to insert an instruction. You will see "Run <time>". Scroll through the operation list using the arrow keys to the Temperature Control and press [ENT]. Now scroll through the list until you find Cooldown <temp>. Press [ENT].

Cooldown <temp>.
Key in Temp 0 F

To cooldown the load to 135 Degrees Fahrenheit/Celsius, press [1][3][5].

002: Cooldown 135 F
003: END OF OPERATION

1-i 2-d 3-e 5-s 0-exit

Now using the arrow keys, place the active line to the top line.

003 END OPERATION

1-i 2-d 3-e 5-s 0-exit

Press 1-i to insert an instruction. You will see "Run <time>". Press [ENT].

Run <time>
Key in time 0:00

ENTER= accept

To run a total of five minutes, press [5][0][0]

002: Cooldown 135 F
003: Run 5:00
004: END OF OPERATION
1-i 2-d 3-e 5-s 0-exit

This operation tells the controller to cool the load down to below 135 Degrees Fahrenheit/Celsius or run a total of five minutes attempting to cooldown to below 135 Degrees Fahrenheit/Celsius.

After you have programmed the operation, press 0-exit then press 1=Ops to enter another operation and follow this guideline.

Programming Formulas

Name the Formula

From the Waiting to Load screen, enter a valid level 6 or 7 password. Select 2=Program. Select 2=Formulas

Key in Formula # 0

ENTER= Accept NO = Exit

Scroll or enter the number that you wish to program and press [ENT].

1:001 ?formula?
002 END FORMULA
3-e 5-s 0-exit

The first line is the active line and all editing operates on the contents of that line. Line 4 on the LCD list the editing options that are possible. 3-e is for editing the top line. 5-s scrolls the LCD screen left and right. Only 20 characters may display on a line and this option allows more of the line to be viewed. Press [3] to edit.

Formula # 1
CLR= Set to Unused
ENT= Edit Name
0 = exit

Press the [CLR] key to set too unused. Press the [ENT] key to edit the formula name.

—
ENT= Character # 00
YES = Left NO = Right
YES + NO = Accept

The cursor (appears as a flashing line) the character position to be edited. With the cursor in position, key in the numerical code (see the ASCII reference) for the

desired character. For example if you are programming Sheets. Press [8][3] then press [ENT]. The S will be shown now press the [NO] key to move the cursor right.

S_
ENT= Character # 83
YES = Left NO = Right
YES + NO = Accept

Continue with this sequence until you have programmed the desired formula name.

S=[8][3] [ENT] [NO]
h=[1][0][4] [ENT] [NO]
e=[1][0][1] [ENT] [NO]
e=[1][0][1] [ENT] [NO]
t=[1][1][6] [ENT] [NO]
s=[1][1][5] [ENT] [NO]
[YES]+[NO]

1:001 Sheets
002 END FORMULA

3-e 5-s 0-exit

Now using the arrow keys, place the active line to the top line. Line 4 on the LCD lists the editing options that are possible. 1-i insert. 2-d delete. 3-e edit. 4-m macro shows only Operation Names no instructions. 4-n returns display to normal viewing Operation Names and instructions. 5-s shift display. 0-ex exit.

002 END FORMULA
1-i 2-d 3-e 4-m 5-s 0-ex

Press 1-i. This gives us another list of options. From here we can insert an operation from our operations that was programmed, insert an instruction from the same list that was available in programming operations list, or insert an entire formula. Here we will choose 1= Ins. Operation.

1 = Ins. Operation
2 = Ins. Instruction
3 = Ins. Formula
0=exit

Using the arrow keys, scroll through the operations list until you reach the desired operation to be inserted. We will use an operation that we have programmed named INITIAL HEAT. Following will be an example of what is entered into the control.

001: INITIAL HEAT
002: Inlet Temperature 600.F
003: Outlet Temperature 200.F
004: Run Time 3:00
005: END OF FORMULA

Using the arrow keys, scroll until the active line is on top.

005: END OF FORMULA

1-i 2-d 3-e 4-m 5-s 0-ex

Press 1-i. Scroll through the operations list until you reach the desired operation to be inserted. We will use an operation we programmed named HI TEMP HEAT CYCLE. Following will be an example of what is entered into the control.

006: HI TEMP HEAT CYCLE
007: Recirculation On
008: Inlet Temperature 600.F
009: Outlet Temperature 200.F
010: Run Time 14:00
011: END OF FORMULA

In our HI TEMP HEAT CYCLE operation that we have placed into the formula, we have decided that we want to dry for 16:00 minutes instead of 14:00 minutes. Using the arrow keys, scroll until the active line (010 Run Time 14:00) is on top.

010: Run Time 14:00
011: END OF FORMULA

1-i 2-d 3-e 4-m 5-s 0-ex

Now press 3-e and enter the desired run time [1][6][0][0].

Run Time
Key in time 16:00

The HI TEMP HEAT CYCLE operation in this formula will now be entered into the control as follows.

006: HI TEMP HEAT CYCLE
007: Inlet Temperature 600.F
008: Outlet Temperature 200.F
009: Run Time 14:00
010: END OF FORMULA

Using this same procedure, you can edit any of the operations for any of the formula. This does not change the operation in your list of operations, only in the formula that you are programming. After we have entered operations into our formula we can press 4-m to see what operations that we have in our formula.

INITIAL HEAT
HI TEMP HEAT CYCLE
END FORMULA
1-i 2-d 3-e 4-n 5-s 0-ex

To return to the normal viewing press 4-n.

Defining Instructions

Run Time

Time programmed in MM:SS (MM:SS > 0 Constitutes a step. A value from 0 to 99:99 can be entered.

Cylinder Rotations

Rotate CW Time

Describes the forward rotation time in ### seconds (0 to 998) for the reversing action of the dryer basket. If set at 999, the dryer basket will rotate forward only.

Rotate CWW Time

Describes the reverse rotation time in ### seconds (0 to 998) for the reversing action of the dryer basket. If set at 999, the dryer basket will rotate reverse only.

Dwell Timer

Describes the dwell time to occur between forward and reverse rotation time in ### seconds (0 to 998) for the reversing action of the wash motor. *If set at 999, then dryer will not rotate however if a temperature instruction is programmed in the same step, the basket will rotate automatically.*

Temperature Control

Inlet <temp>

The inlet temperature is a programmed in Fahrenheit 0 to 600 or Celsius 0 to 350. This instruction is the maximum inlet temperature desired. This instruction needs to be reprogrammed after every run time. It is not retentive.

Outlet <temp>

The outlet temperature is a programmed in Fahrenheit 0 to 600 or Celsius 0 to 350. This instruction is the desired outlet temperature at the outlet of the dryer or the exhaust duct. This instruction needs to be reprogrammed after every run time. It is not retentive.

Note: Programmed Inlet and outlet temp should remain the same in each step of the formula unless there is very compelling reasons to change them. Changing them resets the PID firing rate control loop.

Cooldown <temp>

The cooldown temperature is a programmed in Fahrenheit 0 to 600 or Celsius 0 to 350. This instruction is used to cool the temperature to the programmed value. It is not retentive.

Max Valve <pos.>

Max Valve Position is a limit. Setting it will not let the control ask for more firing rate than the set point. The maximum valve position is programmable from 0 to 4095. This instruction controls the amount of gas entering the burner. The amount of gas entering the burner is called the fire rate. It controls the amount of heat available to the dryer. If the position is set to 0, the valve is closed. If the position is set to 4095, the valve is full open. This instruction IS retentive. The position will remain the same unless another instruction is programmed.

Algorithm Options**Inlet <time><temp>**

This instruction is programmed in Fahrenheit 0 to 600 or Celsius 0 to 350. It is also programmed in minutes and seconds from 0 to 99:99. This instruction instructs the controller to record the time when the inlet temperature is below the programmed temperature value. If the elapsed time exceeds the programmed time, the step is cancelled. This algorithm is used to declare dry.

Outlet <time><temp><temp>

This instruction is programmed in Fahrenheit from 32 to 240 or 0 to 115 Celsius for the high temperature and programmed in Fahrenheit from 32 to 240 or 0 to 115 Celsius for the low temperature. It is also programmed in minutes and seconds from 0 to 99:99. This instruction measures the rate of the outlet temperature rise. This cancels the remainder of the current step if the outlet temperature rises from the low to the high within the time selected. On a steam dryer, the outlet temperature can be stopped or one temperature achieved by setting the high and the low temperature values to the same number and setting the time to 99:99 which will end the formula.

Hum. #1 <set><time>

This instruction is set from 0 to 255 and for a specified time from 0 to 99:99 minutes and seconds. The lower the set point, the dryer the goods. This measures the humidity sensor #1 for the specified set value and time. It is usually a good idea to have at least 2:00 minutes in the humidity time.

Aux. #2 <set><time>

This instruction is set from 0 to 255 and for a specified time from 0 to 99:99 minutes and seconds. The lower the set point, the dryer the goods. This measures a decreasing 4 to 20 mA auxiliary device for the specified set value and time.

Discharge Selections

Auto Discharge Front

This instruction is programmed at the end of the formula to instruct the dryer to automatically discharge the goods from the front.

Auto Discharge Rear

This instruction is programmed at the end of the formula to instruct the dryer to automatically discharge the goods from the rear.

Note: Auto discharge unlike washer discharge receives rotation instructions at the end of the formula.

Advanced Functions

Advanced Functions are a set of instructions that allow the user to program powerful enhancements and decision-making loops into a formula. Total "Flow Control" of the formula can be based on Operator Input during formula execution. Complete knowledge of these functions is essential if they are to be successfully implemented.

Prompt

The Prompt instruction is used to give messages to the operator on the LCD display. Up to 32 prompts may be programmed by accessing the Vocab editor in the program menu system of the MicroPulse Dryer controller. A prompt may be any message up to 16 characters long. To display a prompt during a formula execution, insert the correct Prompt and combine it with a signal.

Label

The Label instruction is used to mark a spot in a formula. Up to 16 different labels (Labels 1-16) may be inserted into a formula for reference. In addition, Label 17 is always the first instruction of a formula and Label 18 is always the last instruction of a formula. Label 19 is always the Resume label. The Label positions are recorded at formula execution and are used for references of the branching instructions. (See <Signal YES/NO>, <Compare Count>, and <GOTO Label>)

SIGNAL YES/NO

The Signal YES/NO instruction is a flow control instruction, which branches to Labels based on operator input. The Signal YES/NO instruction is usually combined with the Prompt instruction to display a message to the operator. The operator's response to the message must be framed as YES or NO. Depending on the response, formula execution is altered according to the desired action needed. Consider the following dryer loop:

```
006:  ***** Label 1 *****
007: HI TEMP HEAT CYCLE
008:  Inlet Temperature 600.F
009:  Outlet Temperature 200.F
010:  Run Time 14:00
011:  Tumble Only
012:  Dwell Timer 999 Seconds
013:  Run Time 0:00
014:  Prompt: Check Load !!
015:  Prompt: Is Load Dry ?
016:  Signal [Yes] = Resume [No] = Label 1
017:  Run Time 0:00
018: COOLDOWN
019:  Cooldown When Temp > 135.F
020:  Run Time 5:00
021: END OF FORMULA
```

Label 1 is inserted on line 6 of the formula. This is the temperature adjustment and main drying portion of the formula. Prompts are programmed for the operator to “Check Load!! and Is Load Dry?” The display will show:

Display 1: Check Load !!
Display 2: Is Load Dry ?
Display 3: Blank
Display 4: [ENT]+[YES]or[NO]

Line 16 of the formula will direct flow of the formula based on the acceptance of the dryness. If the load is dry, then GOTO Label 19 (RESUME FORMULA) is executed and the Cooldown operation begins. If the load is not dry, then GOTO Label 1 (line 6) is executed and the temperature is adjusted and the Hi Temp Heat Cycle operation is re-executed. Note the loop will be repeated as long as the operator continues to answer NO.

COUNT# Adjust

This instruction operates on one of the five available counters. Counters #1 through #5 are initialized to zero at the initial formula execution. Each

of the five counters may be independently changed in the formula. These counters may be used to direct flow of the formula based on their values. A counter can be Incremented or set to Zero. The maximum value of a counter is 99.

COMPARE COUNT #

This instruction is used to program formula flow control based on the contents of the counters. Counters may be compared to values from 0 to 99 and counters may be compared to other counters. The compare is always framed as: COUNTER COMPARED TO VALUE - Is Counter X greater than Value (value can be 0 - 99), or COUNTER COMPARED TO COUNTER - Is Counter X greater than Counter Y. If the statement is true, then a branch is executed to the indicated label. In the formula, the instruction appears as: Cnt #1 > 1 GOTO 1 (If counter #1 is greater than 1, then GOTO Label 1), and Cnt #1 > Cnt #2 GOTO 1. The Compare Count# instruction can be used in the above formula (see Signal YES/NO) to limit drying to 3 adjustments in the following way:

```
006:  ***** Label 1 *****
007:  Increment Counter 1
008:  HI TEMP HEAT CYCLE
009:  Inlet Temperature 600.F
010:  Outlet Temperature 200.F
011:  Run Time 14:00
012:  IF Counter 1 > 2 GOTO Label 2
013:  Tumble Only
014:  Dwell Timer 999 Seconds
015:  Run Time 0:00
016:  Prompt: Check Load !!
017:  Prompt: Is Load Dry ?
018:  Signal [Yes] = Resume [No] = Label 1
019:  Run Time 0:00
020:  ***** Label 2 *****
021:  COOLDOWN
022:  Cooldown When Temp > 135.F
023:  Run Time 5:00
024:  END OF FORMULA
```

The Operator will be prompted to check the dryness of the load two times and a maximum of three Hi Temp Heat Cycles can be executed. Counter 1 is incremented (line 7) in the adjustment step each time it is executed. After execution of the step, Counter 1 is checked to see if three adjustments have been made (line 12). The dryness check is bypassed by branching to Label 2 (line 20).

GOTO LABEL #

The GOTO Label# instruction causes an unconditional branch to the indicated label. This can be used to make even more powerful flow control formulas. The GOTO Label# can be used to add a new message to the Supervisor indicating that problems with the dryer is occurring. The supervisor can then decide whether to try to dry the load again or continue running the formula.

```
006:  ***** Label 1 *****
007:  Increment Counter 1
008:  HI TEMP HEAT CYCLE
009:  Inlet Temperature 600.F
010:  Outlet Temperature 200.F
011:  Run Time 14:00
012:  IF Counter 1 > 2 GOTO Label 2
013:  GOTO Label 1
014:  Tumble Only
015:  Dwell Timer 999 Seconds
016:  Run Time 0:00
017:  Prompt: Check Load !!
018:  Prompt: Is Load Dry ?
019:  Signal [Yes] = Resume [No] = Label 1
020:  Run Time 0:00
021:  ***** Label 2 *****
022:  Zero Counter 1
023:  Prompt: Call Supervisor!
024:  Prompt: Load Not Dry !!
025:  Prompt: Try Again ?
026:  Signal [Yes] = Label 1 [No] = Resume
027:  COOLDOWN
028:  Cooldown When Temp > 135.F
029:  Run Time 5:00
030:  END OF FORMULA
```

If three dry adjustments have been made, the formula branches to Label 2 (line 21). The counter is set to zero and the supervisor is prompted for a decision on whether to adjust dry again or continue without further drying. If drying is tried again, Counter #1 has been set to zero to allow three more adjustments. If no further adjustment is needed, the Cooldown operation is executed.

Set Parameters

This instruction is not used in the MicroPulse Dryer controller software.

Compare Weight

This instruction is not used in the MicroPulse Dryer controller software.

Compare Sensor #1

This instruction is not used in the MicroPulse Dryer controller software.

Compare Sensor #2

This instruction is not used in the MicroPulse Dryer controller software.

Auxiliary Functions

Enable Recirc.

This instruction enables recirculation.

Signal

This instruction turns on an audible and a visible alarm to notify the wash operator of a wash condition.

Tumble Only

This instruction allows the basket to rotate without the blower motors being turned on.

Lint Strip

This instruction is programmed in minutes and seconds from 0 to 99:99. It is the programmed time needed to strip the lint filter.

Aux. Bypass

This instruction is used to bypass a decreasing 4 to 20 mA auxiliary device.

Aux Out #1-7

This instruction is programmed in minutes and seconds from 0 to 99:99. The programmed time will turn on the specified auxiliary output.

Notes:

Passwords Levels and Access Rights

The MicroPulse Dryer controllers are setup with an eight-level password system. Formula programming, manual operations, and maintenance functions are accessible only after entering the appropriate password. The machine is programmed with default passwords at the factory but the user can change them after the machine is entered into service. To change the passwords, a valid level 7 password must be entered. From the Waiting to Load screen enter a valid level 7 password. Select 1=Setup. Select 1=Machine Setups. Select 4=Passwords. Using the arrow keys, scroll to the password that needs to be changed or viewed. A password consists of 1 to 6 numbers. Examples are 1 or 080499. Using a six-digit password is recommended. A password control log is also a recommended practice to keep track of who has each level of password.

Level	Password Code	User	Date	Remarks
1	_____			
2	_____			
3	_____			
4	_____			
5	_____			
6	_____			
7	_____			
8	_____			

Default Password Setups

Level	Default Password
1	111111
2	222222
3	333333
4	444444
5	555555
6	666666
7	777777
8	888888

Function	1	2	3	4	5	6	7	8
Cancel Steps	x	x	x	x	x	x	x	
Access Totals		x	x	x	x	x	x	
Manual Operation			x	x	x	x	x	
Maintenance			x	x	x	x	x	
Clock			x	x	x	x	x	
Cancel Watchdogs				x	x	x	x	
Program						x	x	
Machine Setups							x	
Freeze Timers								x

Cancel Steps

This function is used to skip steps in a formula or to abort a formula that is executing. To cancel a step, press the [NO] key to pause the formula.

Formula # 1
Step # 2 Line 15
PAUSED! [YES] Starts
T = 1:45 S = 5:00

Advancing in a Formula

Enter a valid password level 1 through 7. Press the [UP] arrow key to advance the formula to the desired step. The controller will advance to the next run instruction in the formula.

Formula # 1
Step # 4 Line 63
PAUSED! [YES] Starts
T = 1:50 S = 2:00

Press the [YES] key to resume the formula at the new step.

Canceling a Formula

If a formula is cancelled, time accumulated for that formula is added to the totals.

Formula # 1
Step # 4 Line 63
HI TEMP HEAT CYCLE
T = 1:55 S = 4:57

To abort a formula, enter a valid password level 1 through 7. Press the [ENT] and the [NO] keys simultaneously to clear the current formula.

Waiting for Dryer
to Unload!!

Press [YES] Key Continue

Press the [ENT] and the [NO] keys simultaneously to the "Waiting to Load" display.

Waiting for Dryer
to Receive Load!!
Depress [YES] Key to
Select Formula

Access Totals

This function allows the user to list various statistics such as formula run times and formula usage. From the "Waiting to Load" display, enter a valid password level 2 through 7.

1=Setups 2=Program
3=Maint. 4=Diagnos
5=Totals 6=Clock
Selection? 0=exit

Select 5=Totals

1=Review Totals
Blank Line
3+Clr= Clr Run Data
Selection? 0 = Exit

Pressing 1=Review Totals the LCD will display the following.

1=View Run Time Data
2=View Event History
Blank Line
Selection? 0=exit

Press 1=View Run Time Data to display the number of formula run executions of the displayed formula since the last time the last time run time data was reset. The total minutes spent running the displayed formula is also shown.

Formula 1
Total Runs = 14
Tot. MMMSS= 824
Arrows Scroll 0=exit

Press 2=View Event History to view the last 101 formulas executed. The data for the most recent is displayed. Use the arrow keys to scroll. The start date, start time, formula name, run time, heat on time, loading time and the unloading times are displayed for each formula execution. The time display shows a number for the formula position. For example, the number 1 means that the date in the display is for the last run formula. The number 5 means that the data in the display is for the 5th preceding formula run.

D= 08-04-00 (start date) T= 11:45 (start time)
Formula # 1 (formula name)
R= 36:45 (formula run time) H= 5:30 (satisfy time)
L= 2:34 (load time) U= 2:54 (unloading time)

Maintenance

This function allows the user to operate various machine functions manually. From the "Waiting to Load" display the user can enter a valid password level 3 through 7.

1=Setups 2=Program
3=Maint. 4=Diagnos
5=Totals 6=Clock
Selection? 0=exit

Select 3=Maint.

1=Input/Output Tests
2=Control Tests
3=Maintenance
Selection? 0=exit

Select 1= Input/Output Tests

The following is a list of inputs and outputs that may be on or off. The outputs can be toggled on or off by pressing the [YES] key. Use the arrow keys to scroll.

Control Power On Input	Air Blocking Valve Output
Front Door Open Input	Open Front Door Output
Front Door Closed Input	Back Door Open Input
Open Back Door Output	Back Door Closed Input
Fan Door Closed Input	Emerg. Stops OK Input
Lint System Strip Output	Warning Bell Output
Lower Rear Output	Lower Front Output
Lift Front ½ Up Output	Lift Front Full Output
Lift Rear Up Output	Dryer Horizontal Input
Front Up ½ Input	Front Up Full Input
Rear Up Full Input	Baskets O/L's OK Input
Rotate CW Output	Rotate CCW Output
Baskets Rotating Input	Main Fan O/L's OK Input
Burner Fan O/L's OK Input	Turn On Fans Output
Doors Closed Limit Input	Main Fan Suction Input
Burner Fan Suction Input	Fan Aux. Switches Input
Fireeye Needs Reset Input	Lint System Temp. OK Input
Lint System Pres. OK Input	High Temp. Limit OK Input
Fire RQ Off Status Input	Allow Fireeye Output
Main Fuel Status Input	Recirc. Valve Output
DC Alarm Output	Spare Input
Request Front Up Input	RQ Back Door Open Input
RQ Back Door Closed Input	RQ Dryer Horizontal Input
RQ Basket CW Rotate Input	RQ Basket CWW Rotate Input

Press 0 to exit.

1=Setups	2=Program
3=Maint.	4=Diagnos
5=Totals	6=Clock
Selection?	0=exit

Select 3=Maint.

1=Input/Output Tests
2=Control Tests
3=Maintenance
Selection? 0=exit

Select 2= Control Tests

1=Test Front Panel
2=Board Responses

Selection? 0=exit

Select 1=Test Front Panel

Press all key and buttons one at a time. The time display will show a number corresponding to the location of the active switch. The LCD will also show the corresponding number to the location of the active switch. If the [up arrow] key is being pressed the time and the LCD will displays will show the following.

Time 00:08
P.B./key 8 is pushed
YES + NO = Exit

If no number is displayed, either the switch is faulty or the corresponding electrical circuit has a bad component. Press [YES] + [NO] to exit.

1=Test Front Panel
2=Board Responses

Selection? 0=exit

Select 2=Board Responses

I/O Rack #1
No Responses 0

Arrows Scroll 0= exit

By using the arrow keys, the user can determine if there is a possible I/O rack problem. Due to the nature of the electronic timing signals, the I/O racks will fail to respond to the controller. The controller will repeat the request until the board responds. If the controller receives four sequential no-responses, an error message is displayed. An excessive number of repeat requests may indicate a failing I/O rack or a bad connection. Press [0] to exit.

1=Test Front Panel
2=Board Responses

Selection? 0=exit

Press 0 to exit.

1=Input/Output Tests
2=Control Tests
3=Maintenance
Selection? 0=exit

Select 3=Maintenance

Using the arrow keys, scroll to examine the preventative maintenance watchdog schedule of the machine. The LCD (for example only) will display the following.

DRIVE COMPONENTS
Next Service = 26
0= exit

This tells the user that the drive components preventative maintenance schedule will be due in 26 (26 used for example only) machine hours. Please note that machine hours accumulate only while the machine is executing a formula. Exit from the control.

Clock

The clock is used to track when a formula was executed and for reports on the optional PulseNet module. To set the clock, enter a valid level 3 through 7 password from the Waiting to Load screen.

1=Setups 2=Program
3=Maint. 4=Diagnos
5=Totals 6=Clock
Selection? 0=exit

Select 6=Clock

Date= 00:00:00
Enter New Date
Date= 00:00:00
ENTER= Accept No= exit

Enter the day, month, and year. For example the date is July 4, 2000 press [0][8][0][4][0][0].

Date= 00:00:00
Enter New Date
Date= 08:04:00
ENTER= Accept No= exit

Press [ENT].

Time= 00:00:00
Enter New Time
Time= 00:00:00
ENTER= Accept No= exit

The clock is in a 24-hour format also known as European. Enter the hour, minutes, and seconds. For example, if the time is 3:15:33 PM, press [1][5][1][5][3][3].

Time= 00:00:00
Enter New Time
Time= 15:15:33
ENTER= Accept No= exit

Press [ENT].

Cancel Watchdogs

This allows the user to cancel maintenance and preventative maintenance watchdogs. The fault will be displayed on the LCD any time the controller detects an error condition. The error message will indicate the type of fault. Machine operation will be halted until a valid level 4 through 7 password is entered. Refer to troubleshooting for a list of error messages and possible corrective actions.

Call Maintenance!!
Low Air Pressure!

Enter a valid level 4 through 7 password.

Formula # 1
Step # 4 Line 63
PAUSED! [YES] Starts
T = 1:50 S = 2:00

Setups

This allows the user to enter the user-defined setups. Refer to user-defined setups. From the Waiting to Load screen, enter a valid level 6 or 7 password.

1=Setups 2=Program
3=Maint. 4=Diagnos
5=Totals 6=Clock
Selection? 0=exit

Select 1=Setups (Please see Setups section)

Program

This allows the user to enter the 2=Program selection. Refer to Program section. From the Waiting to Load screen, enter a valid level 6 or 7 password.

1=Setups 2=Program
3=Maint. 4=Diagnos
5=Totals 6=Clock
Selection? 0=exit

Select 2=Program

Machine Setups

This allows the user to setup the user defined watchdog setups. From the Waiting to Load screen, only a valid level 7 password will allow access. Refer to Watchdog/Setups section.

1=Setups 2=Program
3=Maint. 4=Diagnos
5=Totals 6=Clock
Selection? 0=exit

Select 1=Setups

1=Machine Setup
2=Maintenance Setup
3=Clear Ram Vocabs
4=Passwords 0=exit

Select 1=Machine Setup

Freeze Timers

This allows the user to freeze the controls timers while not in use by entering a valid level 8 password all of the control timers are frozen. After the days production it is good to make sure the formula is finished processing to freeze the timers. This is for the total reports. This is known as sleeping the machine. Pressing any key will wake the machine and resume all timers.

Maintenance Prompts

Because the maintenance prompts can be customized to suit the individual needs of the user, responsibility for completing maintenance rests with the user. There is a total of 32 maintenance prompts for the user.

For the recommended preventative maintenance, please refer to the manufacturer for details.

Setting up the Preventative Maintenance Program

From the Waiting to Load screen, enter a valid level 7 password.

1=Setups 2=Program
3=Maint. 4=Diagnos
5=Totals 6=Clock
Selection? 0=exit

Select 1=Setup.

1=Machine Setup
2=Maintenance Setup
3=Clear Ram Vocabs
4=Passwords 0=exit

Select 2=Maintenance Setup

Maintenance # 1
MAINTENANCE # 1
Use arrows to scroll
Enter = Accept No = Exit

Press [ENT]. The cursor (appears as a flashing line) the character position to be edited. With the cursor in position, key in the numerical code (see the ASCII reference) for the desired character.

For example if you are programming CLEAN MACHINE. Press [6][7] then press [ENT]. The C will be shown now press the [NO] key to move the cursor right.

CAINTENANCE # 1
ENT= Character # 67
YES = Left NO = Right
YES + NO = Accept

Continue with this sequence until you have programmed the desired operation name.

C=[6][7] [ENT] [NO]
L=[7][6] [ENT] [NO]
E=[6][9] [ENT] [NO]
A=[6][5] [ENT] [NO]
N=[7][8] [ENT] [NO]
space=[3][2] [ENT] [NO]
M=[7][7] [ENT] [NO]
A=[6][5] [ENT] [NO]
C=[6][7] [ENT] [NO]
H=[7][2] [ENT] [NO]
I=[7][3] [ENT] [NO]
N=[7][8] [ENT] [NO]
E=[6][9] [ENT] [NO]
space=[3][2] [ENT] [NO]
space=[3][2] [ENT] [NO]
space=[3][2] [ENT] [NO]
[YES]+[NO]

The LCD display will now read as follows:

CLEAN MACHINE
Interval= 0
Key in Interval Hrs.
ENTER = Accept

The next step is to set up the desired maintenance interval. The screen will show the currently programmed interval in hours. Enter the desired interval using hours from 1 to 99999. We will enter 80 hours for our example. Press [8][0][ENT]. The LSD display now reads as follows:

CLEAN MACHINE
Next Service= 80
Password Resets Hrs.
ENTER = Accept

Key in a valid level 7 password to make the interval change take effect. The LCD display will read as follows:

1=Machine Setup
2=Maintenance Setup
3=Clear Ram Vocabs
4=Passwords 0=exit

If required, Press 2=Maintenance Setup and follow this guideline. If not, exit from the controller.

Key Pressing During Formula Execution

While a formula is being executed you can get very useful information by pressing and holding any of the numeric keys. Following will be examples of information by pressing these keys.

Pressing the [1] key displays information on the programmed Inlet and Outlet temperature controls.

Inlet Temp. Control
Control Temp. =
Outlet Temp. Control
Control Temp. =

Pressing the [2] key displays the programmed Cooldown temperature.

Cooldn Temp. Control

Control Temp. =

Pressing the [3] key displays the programmed Inlet Algorithm. If no algorithm is programmed, the following will be displayed.

Inlet Algorithm

Not Prog. This Step

Pressing the [4] key displays programmed Outlet Algorithm. If no algorithm is programmed, the following will be displayed.

Outlet Algorithm

Not Prog. This Step

Pressing the [5] key displays the programmed Humidity #1 and Aux. #2 algorithm set points. Shown below, the algorithm is not programmed.

Humidity #1 12.5
No Set Point Algo.
Auxiliary #2 0.2
No Set Point Algo.

Pressing the [6] key displays the value of the Main Fan and Makeup Air in inches of water. It also displays the maximum valve position setting and actual valve position setting.

2.65" H2O Main Fan
0.07" H2O Make Air
Max. Valve= 4095
Act. Valve= 1485

Pressing the [7] key displays the following.

pT1= 1838 iT= -0521
dT1= 0008 vT= 12mm
pT2= 0400 iT2= +1042
dT2= 0000 vT2= 4095

The notation is as follows:

pT1= Outlet Temperature Proportional component

iT1= Outlet Temperature Integral component

dT1= Outlet Temperature Derivative component

vT1= Outlet Temperature Valve Position desired

pT2= Inlet Temperature Proportional component

iT2= Inlet Temperature Integral component

dT2= Inlet Temperature Derivative component

vT2= Inlet Temperature Valve Position desired

Pressing the [8] key displays programmed reversing times and the timers counting down.

CW= 16 sec 14.5
CCW= 16 sec 16.0
Dwell= 4 sec 4.0

Using the Override Displays

Screen 1

To enter into the override displays, the operator will need to press the Up and Down arrows simultaneously. The following will be a review of screen number 1.

Machine Diagnostic
Machine is OK or Displays a Fault

Line 1 displays that you are in the Machine Diagnostics.

Lines 2, 3, and 4 display the machine status. For example, if the machine was in the load position with the front door open the display would read line 2 Machine not at Run. Line 3 would display Front Door not Closed.

Press the Up arrow to advance to the screens.

Screen 2

Rack #1	Rack #2	
00000000	00000000	(1= On 0 = Off)
Rack #3	Var. Speed	
00000000	00000000	(1= On 0 = Off)

Line 1 displays the rack 1, 1-8 and rack 2, 1-8.

Line 2 displays the rack 1, 1-8 and rack 2, 1-8 status. For example, if outputs 107 and 204 were on the display would read 00000010 00010000.

Line 3 displays the rack 3, 1-8 and Variable Speed.

Line 4 displays the rack 3, 1-8 and rack 4, 1-8 status. For example, if outputs 307 were on the display would read 00000010 00000000.

Screen 3

```
ACInp 1-8   ACInp 9-16
00000000   00000000 (1= On 0 = Off)
DCInp 1-8   DCInp 9-16
00000000   00000000 (1= On 0 = Off)
```

Line 1 displays the AC Inputs 1-8 and 9-16.

Line 2 displays the AC Inputs 1-8 and 9-16 status. For example, if Inputs 7 and 12 were on the display would read 00000010 00010000.

Line 1 displays the DC Inputs 1-8 and 9-16.

Line 2 displays the DC Inputs 1-8 and 9-16 status. For example, if Inputs 7 and 12 were on the display would read 00000010 00010000.

Screen 4

```
Humidity #1      80.3
Hum./Aux #2 68.2
Aux Temp. #1     80
Aux Temp. #1     80
```

This is the actual value of the moisture and auxiliary temperature sensors.

Screen 5

```
Serial Num. = 00000
Hour Meter = 0
00-00-0000 (Software Date) ID#=000 (Arcfiber board setting)
TUMB VER 3.0 R 0.0
```

Line 1 displays the serial number.

Line 2 displays the hour meter.

Line 3 displays the Software date and Arcfiber ID. For example, if the software date was July 4, 2000 and the machine ArcNet ID was 4 the display would read 07-04-2000 ID#4.

Line 4 displays the software name, version number, and revision number.

Screen 6

Item # = 000000
Lot # = 000000
Cust. # = 000000
Weight = 0

In automated systems, this screen displays the item, lot, and customer numbers along with the actual weight being processed in the machine.

Press the Down arrow to advance to back to screen 1.

Time in MM:SS = 00:00
Level in In. = 00.0
Temp. In Deg. = 000F
Cylinder RPM's = 000

Press the [CLR] key to return to the machine state.

Waiting to Receive Load State

If the machine were in the waiting to receive state, the display would read as follows:

Waiting For Dryer
To Receive Load!!
Depress [YES] Key To
Select Formula
Switching to
* The MicroPulse *
Softrol Systems
c. 1988-2002
Softrol Systems, Inc

Formula Execution State

If the machine were executing a formula, the machine would read as follows:

Formula Name	
Operation Name	
Step # 1	Line # 2
T=0:26	S=9:56

Line 1 displays the formula name. For example, if the formula name were Sheets, the display would read Sheets.

Line 2 displays the operation name. For example if the name of the operation were Initial Heat, the display would read INITIAL HEAT.

Line 3 displays the step number and the line number that the formula is executing.

Line 4 displays the total time the formula has been running and the remaining time in the step.

Reinitializing the Front Panel Display

If there is a power interruption to the FPD, the FPD will need to be reinitialized. To reinitialize the FPD press the [UP] and [Down] arrow keys simultaneously. Then the [UP] and [ENT] keys simultaneously.

Copying Memory Contents

All power must be turned off before inserting or removing printed circuit boards. The memory card is very static sensitive device. Always touch the machine before touching the circuit boards. Hold the circuit boards by the edges to minimize contact with the components. This procedure is used to duplicate formulas, operations, setups, calibrations, vocabs, and passwords between machines. This process reduces programming time for multiple machines and achieves standardization among machines. The transfer can be done two different ways. **THIS PROCEDURE IS USED ON NON-AUTOMATED SYSTEMS ONLY** but may be used before any automation is performed. These two procedures copy the Automation Setups causing loading and unloading problems.

1. All power must be turned off before inserting or removing printed circuit boards. Remove the E3-FLOWMEM slot 5 card from the unprogrammed machine and place it into the slot 4 of the programmed machine. Then copy slot 5 to 4.
2. All power must be turned off before inserting or removing printed circuit boards. Remove the E3-FLOWMEM slot 5 card from the programmed machine and place it into the slot 4 of the unprogrammed machine. Then copy slot 4 to 5.

This process replaces whatever is stored on the E3-FLOWMEM card. Be careful not to replace the contents of an unprogrammed E3-FLOWMEM onto the programmed E3-FLOWMEM. Because the procedure is the same for both methods only one method will be explained.

The vocabs are stored on the E3-REMK4A card that is connected to the E3-PRO63K4 card in slot 1. If the user wishes to copy the vocabs along with the setups, formulations, operations, and passwords they will have to be copied to the slot 5 E3-FLOWMEM card. After machine 1 (programmed machine) has been programmed, copy the vocabs.

At the Waiting for Load screen enter a valid level 7 password.

1=Setups 2=Program
3=Maint. 4=Diagnos
5=Totals 6=Clock
Selection? 0=exit

Select 2=Program.

1=Ops2=Formulas
3=Clr Ops 4=Clr Forms
5=Copy 6=Vocabs
Selection? 0=exit

Select 5=Copy.

1=Copy Slot Cards
2=Copy Vocabs

Selection? 0=exit

Select 2=Copy Vocabs.

1=Vocabs to Slot 5
2=Slot 5 to Vocabs
0=exit

Select 1=Vocabs to Slot 5. Be careful not to select 2=Slot 5 to Vocabs. That could potentially change all of your formula, operation, and maintenance names along with all other programmable vocabs.

Copy Vocabs to Slot 5
Key in Password!!!
NO = exit

Enter a valid level 7 password.

Verify

YES to Continue

1=Ops 2=Formulas
3=Clr Ops 4=Clr Forms
5=Copy 6=Vocabs
Selection? 0=exit

Select 5=Copy.

1=Copy Slot Cards
2=Copy Vocabs

Selection? 0=exit

1=Ops 2=Formulas
3=Clr Ops 4=Clr Forms
5=Copy 6=Vocabs
Selection? 0=exit

Now that all vocabs are backed up on the E3-FLOWMEM card, the user will be ready to continue.

Turn off the main circuit breaker of the machine that has not been programmed (machine 2). Remove the E3-FLOWMEM slot 5 card from the machine.

Turn off the main circuit breaker of the machine that has been programmed (machine 1). Place the E3-FLOWMEM card from machine 2 into slot 4.

Turn on the circuit breaker on machine 1.

At the Waiting for Load screen enter a valid level 7 password.

1=Setups 2=Program
3=Maint. 4=Diagnos
5=Totals 6=Clock
Selection? 0=exit

Select 2=Program.

1=Ops 2=Formulas
3=Clr Ops 4=Clr Forms
5=Copy 6=Vocabs
Selection? 0=exit

Select 5=Copy.

1=Copy Slot Cards

2=Copy Vocabs

Selection? 0=exit

Select 1=Copy Slot Cards

1=Copy Slot 5 to 4

2=Copy Slot 4 to 5

Selection? 0=exit

Select 1=Copy Slot 5 to 4

Copy Slot 5 to 4

Key in Password!!!

NO = exit

Enter a valid level 7 password and all formulas, operations, setups, password, and vocabs are now stored on the E3-FLOWMEM card from machine 2.

Turn off the main circuit breaker of the machine 1. Remove the E3-FLOWMEM card from machine 2 and place the E3-FLOWMEM card from machine 3 and follow the procedure beginning with replacing machine 2 with machine 3. If no other machines are to be copied, turn on the main circuit breaker.

Return to machine 2. Place the E3_FLOWMEM card back into slot 5. Turn on the main circuit breaker to the machine.

At the Waiting for Load screen enter a valid level 7 password.

1=Setups 2=Program

3=Maint. 4=Diagnos

5=Totals 6=Clock

Selection? 0=exit

Select 2=Program.

1=Ops 2=Formulas
3=Clr Ops 4=Clr Forms
5=Copy 6=Vocabs
Selection? 0=exit

Select 5=Copy.

1=Copy Slot Cards
2=Copy Vocabs

Selection? 0=exit

Select 2=Copy Vocabs.

1=Vocabs to Slot 5
2=Slot 5 to Vocabs
0=exit

Select 2=Slot 5 to Vocabs. Be careful not to select 1=Vocabs to Slot 5. That could potentially change all of your formula, operation, and maintenance names along with all other programmable vocabs. This will copy all of the vocabs to the E3-REMK4A card allowing the user to view them.

Copy Slot 5 to Vocabs
Key in Password!!!
NO = exit

Enter a valid level 7 password.

Verify

YES to Continue

1=Ops 2=Formulas
3=Clr Ops 4=Clr Forms
5=Copy 6=Vocabs
Selection? 0=exit

Exit out of the control and the user is ready to execute formulas.

Notes:

Hardware Overview

The MicroPulse Controller consists of Slot Cards that reside in an Mb8-K4A (Mother Board). Residing in the processor slot, you will find two cards that attach to each other then plug into the Mb8-K4A. The REM-K4A attaches to the E3-PRO63K4A card. The E3-PRO63K4A then attaches to the Mb8-K4A. In Slot 1 you will find an ACI16 card. In Slot 2 resides an AIO420 card. In slot 3 resides an E3-DCIP16 card. In Slot 5 you will find an E3-FLOWMEM card. In Slot 6 you will find the optional ARCFIBER card. The remaining Slots are empty and used for different machine configurations.

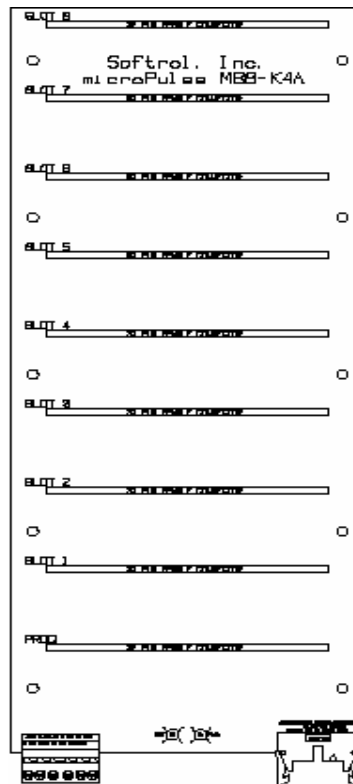

Mb8-K4A (Mother Board)

This board connects all of the cards in the rack. It houses the EEPROM where the manufacturers setups reside and is also the Processor Board for the MicroPulse Controllers. With the Mb8-K4A card mounted into the machine, starting from left to right, there is a 6 pin 250V 10 AMP connector. In Pin 1 you will find a 299 black wire 0 VDC. In Pin 2 you will find a blue wire +15 VDC. In Pin 3 you will find a purple wire +5VDC. In Pin 5 will be a purple wire 0VDC. Next to the 6 Pin connector, you will see two Red LED's. The first LED will flash on and off when the control is resetting itself. The second LED is on steady when there is power to the control. Next you will see the Communication Ribbon Connection to the I DR-8G4 Boards with the Ribbon Red attached on the arrow side of the connector. You will then find 9 Slots for the remaining cards. ***If the Mb8-K4A is to be replaced, please notify Softrol service department for instructions regarding the EEPROM replacement.***

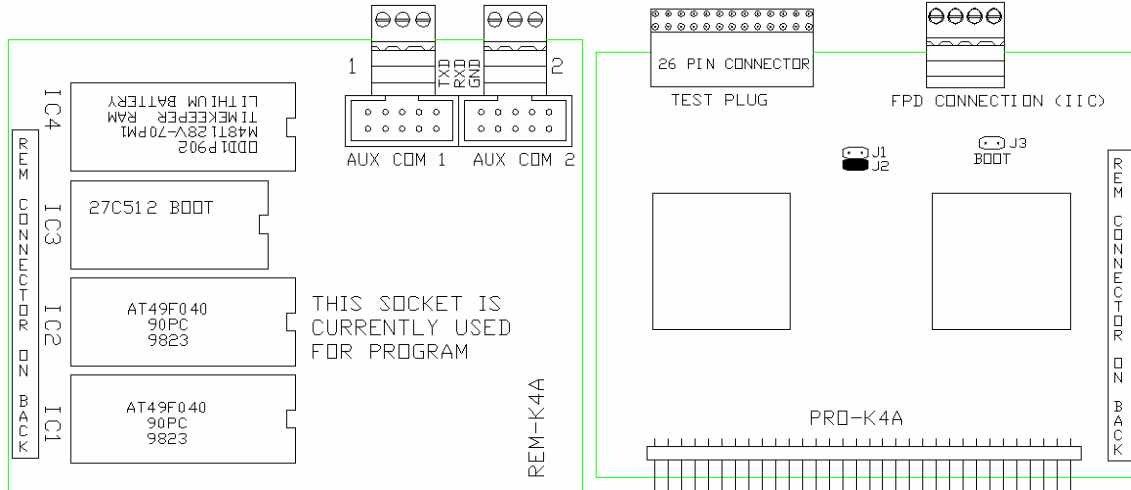

Processor Slot

The REM-K4A and the E3-PRO63K4A cards are housed here. The REM-K4A card is the memory card. This card houses the Timekeeper RAM and the Lithium Battery in the IC4 socket. The IC3 socket contains the Boot memory. The IC2 socket contains an AT49F040 eprom. This socket is currently used for the program. The IC1 socket is open for later use of an AT49F040 eprom. The REM-K4A card also has an Auxiliary COM 1 port and an Auxiliary COM 2 port. The COM 1 is for ModBus communications while COM 2 is for a 232 type communications. The REM-K4A attaches to the E3-PRO63K4A card. The E3-PRO63K4A resides in the Processor Slot of the Mother Board. The E3-PRO63K4A card will have J2 pins jumpered. It will have a four pin IIC or FPD Connection. Pin 1 is for +5VDC. Pin 2 is for the Ground. Pin 3 is for the Clock. Pin 4 is for Data. The Data and Clock is one twisted pair. The Ground and the +5VDC is one twisted pair.

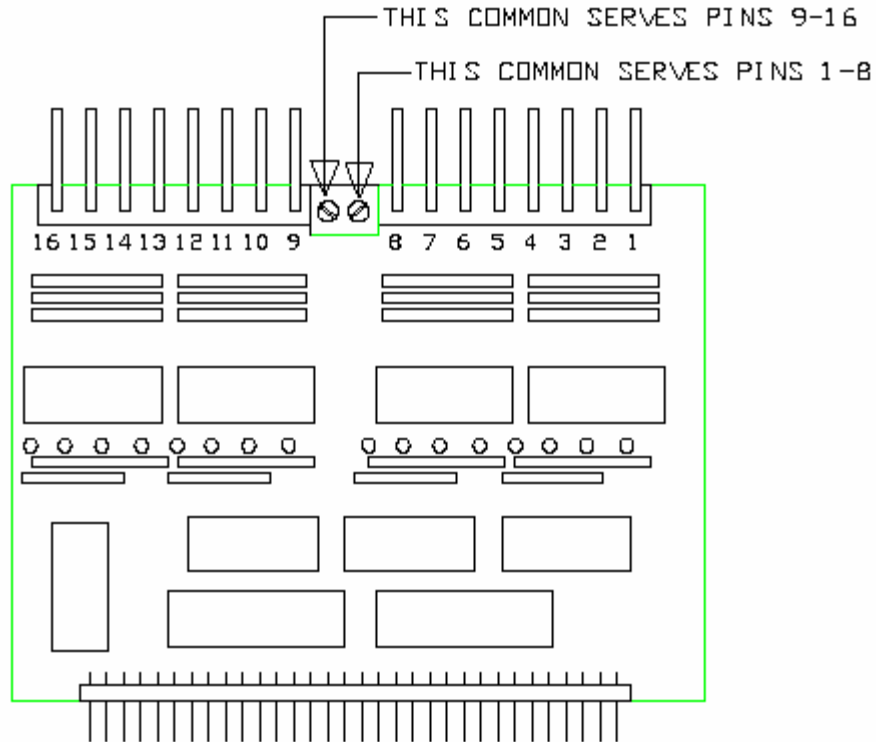

Slot 1 the ACI16

This card is usually used for 24 volts AC and has 16 inputs. LED's correspond to inputs and light up when power is applied. When the input is AC, the LED is orange. This card can be used on two circuits with different commons. With the card residing in its proper slot the first common is Red wire 200. The second common is also a Red wire 200 +24 VDC. The remaining wires are inputs s1-01 through s1-16 and are Blue wires.

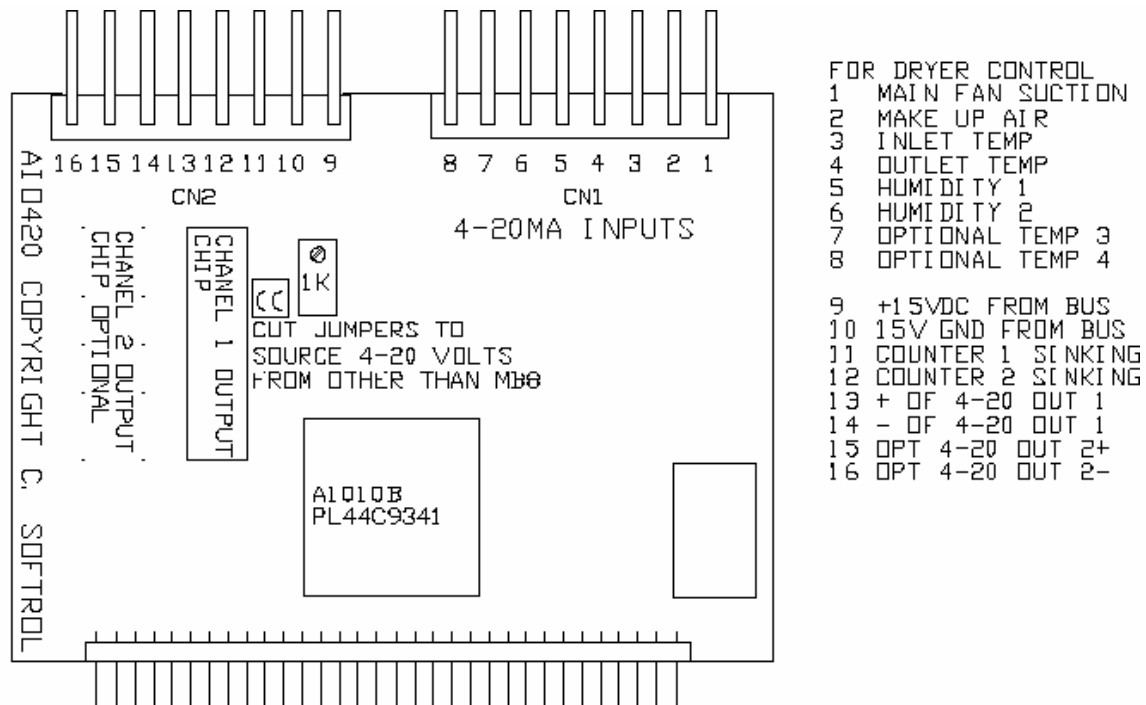

Slot 2 the E3-AIO420

The E3-AIO420 is for 4 to 20 mA inputs and outputs. Pin 1 (S3-01) is a 4 to 20 mA input from the Main Fan Suction. Pin 2 (S3-02) is a 4 to 20 mA input from the Make Up Air. Pin 3 (S3-03) is a 4 to 20 mA input for the Inlet Temperature Probe. Pin 4 (S3-04) is a 4 to 20 mA input for the Outlet Temperature Probe. Pin 5 (S3-05) is a 4 to 20 mA input for the Humidity 1 Probe. Pin 6 (S3-06) is a 4 to 20 mA input for the Humidity 2 Probe. Pins 7 and 8 (S3-07 and S3-08) are for optional temperature probes. Pin 9 (S3-09) is +15VDC from BUS. Pin 10 (S3-10) is 15V ground from BUS. Pin 11 (S3-11) is Counter 1 Sinking. Pin 12 (S3-12) is Counter 2 Sinking. Pin 13 is positive of 4-20 mA output 1. Pin 14 (S3-14) is negative of 4-20 mA output 1. Pin 15 (S3-15) is positive of 4-20 mA the optional output 2. Pin 16 (S3-16) is negative of 4-20 mA the optional output 2.

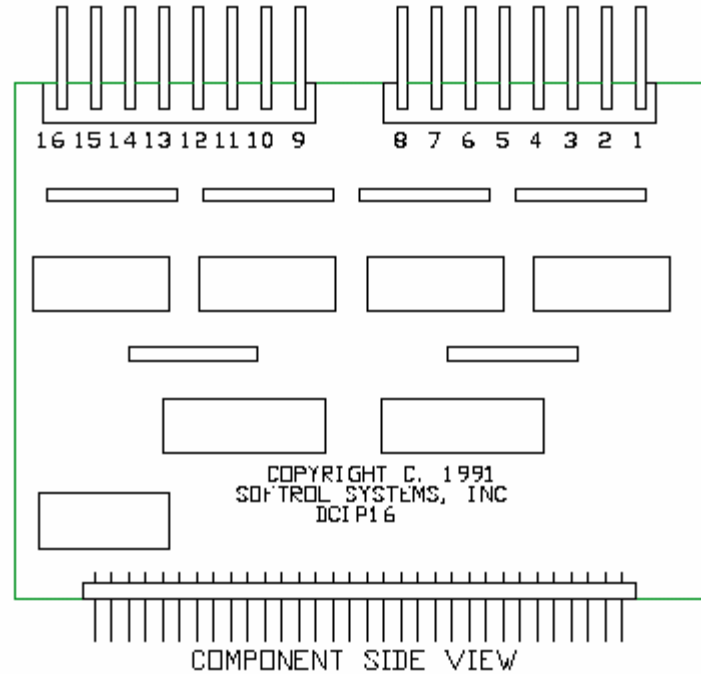

Slot 3 the DCIP16

This card has 16 DC inputs. The voltage of the inputs must be the same as the volts on AGND (0VDC) and +15/24VDC of the mother board. +DC volts is supplied to the card from the motherboard and connecting an input pin to AGND turns on the input. Visual indication of input on condition is a red LED on the back side of the card. The wires are inputs s3-01 through s3-16 and are Black wires.

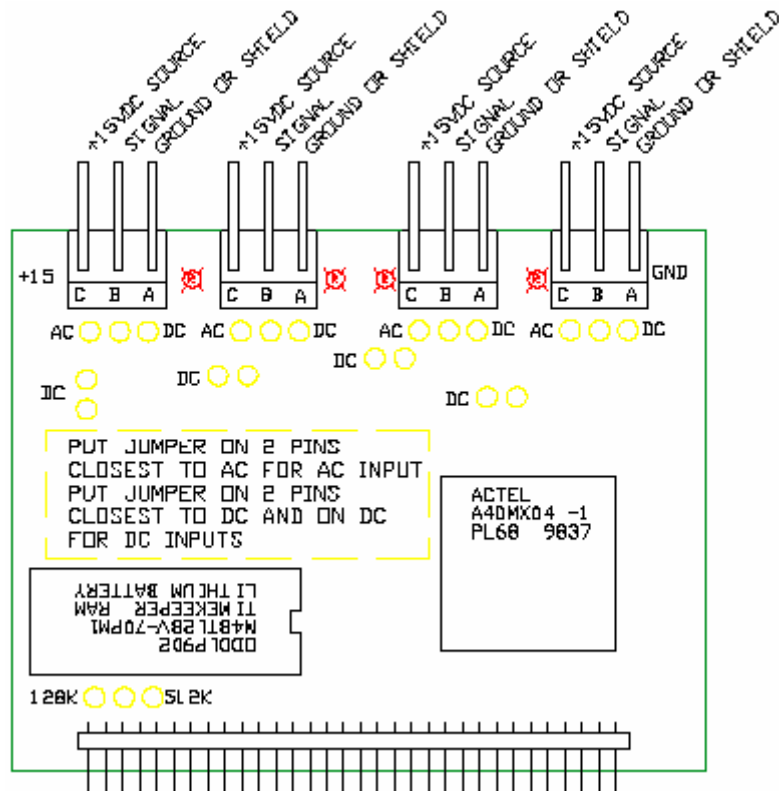

Slot 5 the E3-FLOWMEM128NV

The E3-FLOWMEM128 NV card is a four channel AC or DC memory card. Channel 1 is used for the RPM sensor with the ground in Pin A, the signal in Pin B, and the +15 VDC in Pin C. Channel 2 is a spare. Channel 3 is for the Water Meter with the ground in Pin A, the signal in Pin B, and the +15 VDC in Pin C. Channel 4 is a spare. A Timekeeper RAM and Lithium Battery is also socketed to this card.

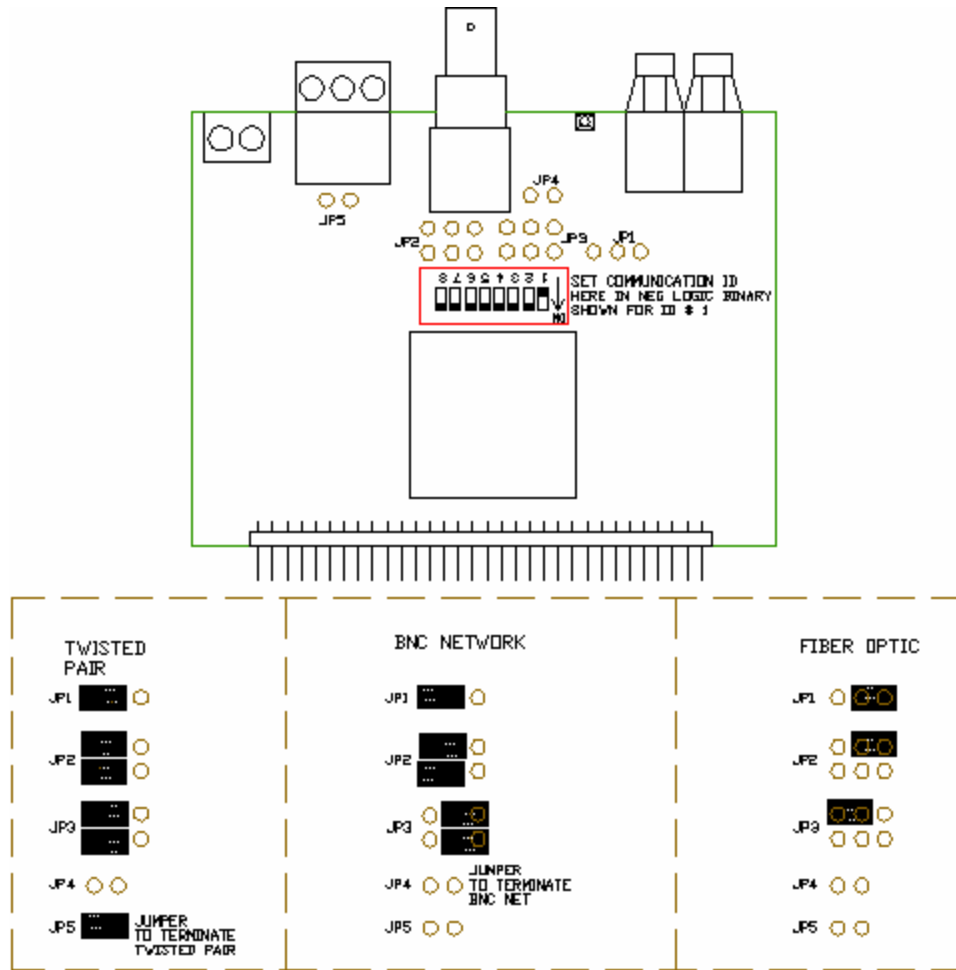

Slot 6 the ARCFIBER

The ARCFIBER card contains an ArcNet Media. The ArcNet Media controller can drive three different types media depending on the jumper configuration. One ArcNet Media is Twisted-pair Communication (TP). To use the TP communications, the card must be jumpered as follows; viewing the ARCFIBER name to your right, JP1 need pins 1 and 2 jumped. JP2 needs both sets of pins 1 and 2 jumped. JP3 needs both sets of pins 1 and 2 jumped. Please note, that if the machine is at the end of the communication loop, JP5 needs to be jumped also.

The second ArcNet Media is COAX Communication. To use the COAX communications, the card must be jumpered as follows: viewing the ARCFIBER name to your right, JP1 need pins 1 and 2 jumped, JP2 needs both sets of pins 1 and 2 jumped, and JP3 needs both sets of pins 2 and 3 jumped. Please note that if the machine is at the end of the communication loop, JP4 needs to be jumped. If a 93-ohm terminator is placed onto the ArcNet connector DO NOT JUMPER JP4.

The final ArcNet Media is Fiber Optic Communication (FO). To use the FO communications, the card must be jumpered as follows: viewing the ARCFIBER name to your right, JP1 need pins 2 and 3 jumped, JP2 needs the top set of pins

2 and 3 jumped, and JP3 needs the top set of pins 1 and 2 jumped. Software must configure the ArcNet controller for back plane mode to properly transmit and receive.

On systems where the machine is connected to a PulseNet network, this board needs to be set so that each individual machine establishes its own identity that is known as the Node ID. To do this the ARCFIBER card needs to be set up. The Node ID for the board is setup by setting the 8-position DIPswitch to the proper binary code representing the particular node number from 0 to 255. The switches are numbered 1 through 8 with 1 being the least significant bit of the node. The ON position represents logic 0; the OFF position represents logic 1. For example, to set the node ID as 31 first convert the decimal to binary, then determine the switch positions.

Switch #	1	2	3	4	5	6	7	8
Decimal	1	2	4	8	16	32	64	128
Binary	Off	On	Off	On	On	Off	Off	On

EXAMPLE: Node ID 101

```

  x  x x  x
x  x    x x
1 2 3 4 5 6 7 8

```

ARCNET
TWISTED PAIR
POLARITY GUIDE

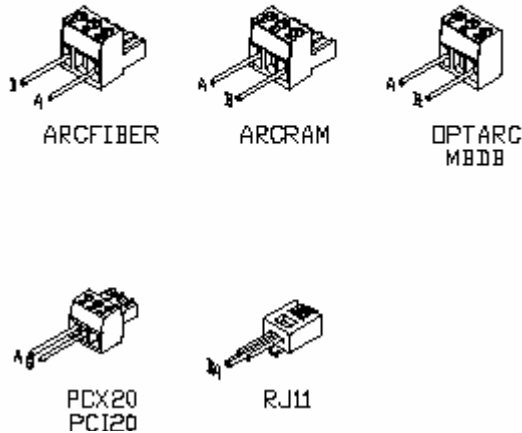

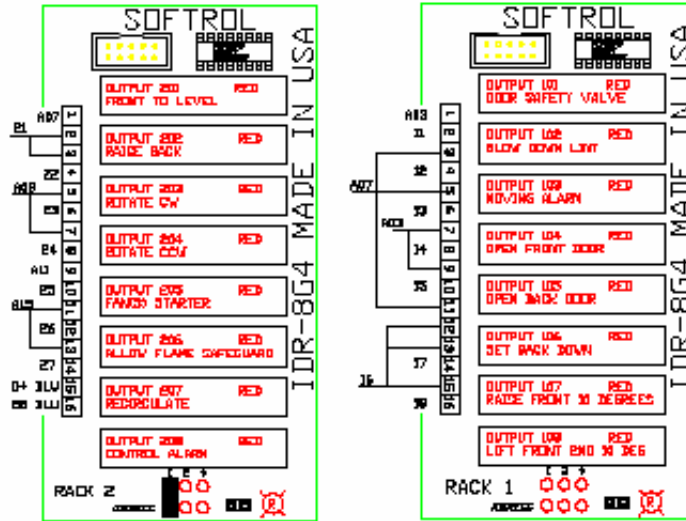

There are two output racks known as IDR-8G4. The IDR-8G4 is an 8 output/input (AC/DC, opto-isolated) interface card called a RACK under 12C control. The card is addressable with eight unique addresses. A fuse tester for the opto modules is built in and located to the right of the red LED. Placing jumpers on the 1, 2, and 4 pins sets the RACK address. Please note that jumper numbers total to one less than the RACK number meaning a RACK address can be setup by subtracting one from the desired RACK number and then installing jumpers to get the desired results. For example if the address for RACK 6 is desired, subtract one from six to get five, then jumper pins 1 and 4. Please review the following example of RACK addresses:

RACK ADDRESS	
	1 2 4
RACK1	
RACK2	
RACK3	
RACK4	
RACK5	
RACK6	
RACK7	
RACK8	

Notes:

Machine Error Faults

One of the advantages of the technology in the MicroPulse Dryer controller is the ability of the controller to monitor the machine and itself. If something out of the ordinary occurs, the controller will sound an alarm and warn the operator of the problem that exists.

Errors require a level four (4) or higher password, to be cleared. Following are examples and how to troubleshoot error faults:

RESET OVERLOADS!

One or more of the overloads have tripped on the Basket Motor, Exhaust Blower Motor or Combustion Blower Motor (not on Steam Dryers).

EMERGENCY STOP!

The emergency stop has interrupted the control circuit.

RESET 15a CIRCUIT!

The 15 amp circuit breaker has been tripped.

FAN DOOR OPEN!

The Exhaust Blower fan door is not fully closed or the controller is not sensing the Door Switch input.

LOW GAS PRESSURE

The gas pressure has dropped below a safe operating range. (Optional- IRI / CSA style Dryers)

I/O Rack #1 Fault

The I²C Chip on I/O Rack #1 did not respond to a request by the MicroPulse Controller CPU via the I²C Cable. Check the condition of the cable for possible damage. Verify the machine setups.

I/O Rack #2 Fault

The I²C Chip on I/O Rack #2 did not respond to a request by the MicroPulse Controller CPU via the I²C Cable. Check the condition of the cable for possible damage. Verify the machine setups.

I/O Rack #3 Fault

The I²C Chip on I/O Rack #3 did not respond to a request by the MicroPulse Controller CPU via the I²C Cable. Check the condition of the cable for possible damage. Verify the machine setups.

I/O Rack #4 Fault

The I²C Chip on I/O Rack #4 did not respond to a request by the MicroPulse Controller CPU via the I²C Cable. Check the condition of the cable for possible damage. Verify the machine setups.

I/O Rack #5 Fault

The I²C Chip on I/O Rack #5 did not respond to a request by the MicroPulse Controller CPU via the I²C Cable. Check the condition of the cable for possible damage. Verify the machine setups.

I/O Rack #6 Fault

The I²C Chip on I/O Rack #6 did not respond to a request by the MicroPulse Controller CPU via the I²C Cable. Check the condition of the cable for possible damage. Verify the machine setups.

Outlet Temp Low

The outlet temperature sensed was equal to or lower than the programmed setup Outlet Temp Lo. Verify the machine setups. Verify the programmed formula. Check the outlet temperature probe (RTD).

Outlet Temp High

The outlet temperature sensed was equal to or higher than the programmed setup Outlet Temp Hi. Verify the machine setups. Verify the programmed formula. Check the outlet temperature probe (RTD).

Max Heat Time Error

The drying time has equaled the programmed time for the Heat Overtime Error setup. Verify the machine setups. Verify the programmed formula. Check for proper air flow.

No Heat Error

The MicroPulse controller did not sense any heat during the formula. Check the temperature probes. Check the slot three E3-AIO420 board for proper operation.

Inlet Temp Low

The inlet temperature sensed was equal to or lower than the programmed setup Inlet Temp Lo. Verify the machine setups. Verify the programmed formula. Check the inlet temperature probe (RTD).

Inlet Temp High

The inlet temperature sensed was equal to or higher than the programmed setup Inlet Temp Hi. Verify the machine setups. Verify the programmed formula. Check the inlet temperature probe (RTD).

Fire Safety Trip

The MicroPulse controller has sensed a problem with the Flame Safeguard Control (Fire-eye or Honeywell). Check the Flame Safeguard Control (Fire-eye or Honeywell) for proper operation or damage. Check Flame Rod or UV Scanner for proper operation or lint build-up.

Main Fan Error

The Exhaust Blower Pressure is too low or not being sensed by the Exhaust Blower Pressure Switch. Verify the Exhaust Blower is functioning and creating 2 to 6 inches of W.C. suction. Check Exhaust Blower Pressure Switch wiring and the Pressure switch. (Optional) The MicroPulse controller did not sense the main fan working properly. Check the main fan for obstructions. Check for lint buildup.

Combustion Fan Error

The Combustion Blower Pressure is too low or not being sensed by the Combustion Blower Pressure Switch. Verify the Combustion Blower is functioning and creating 4 to 12 inches of W.C. pressure (depending upon Dryer model). Check Combustion Blower Pressure Switch wiring and the Pressure switch. (Optional) The MicroPulse controller did not sense the combustion fan working properly. Check the combustion fan for obstructions. Check for lint build up.

Basket Not Rotating

The MicroPulse controller did not sense the basket was rotating. Check the basket rotation proximity switch.

Lint (Lint House) System Pressure Switch

The MicroPulse controller sensed that there is a pressure build up in the lint system. Check the Lint Collector Pressure Switch and check for lint build-up.

Horizontal Switch Error

The MicroPulse controller did not sense the machine is in the horizontal position. Check the horizontal switch.

Door Not Closed

The MicroPulse controller did not sense the machines door(s) were fully closed. Check the door closed switch(s).

The MicroPulse Dryer controller has default operations ranging from operation numbers 33 to 64. These operations may be edited but the operation names may not. These are for the user to use to learn to program by or even to use in their formulations. The MicroPulse Dryer controller also has default formulas ranging from formulas 100 to 128. These formulas and formula names may be edited.

Operation #33 INITIAL HEAT

0001: INITIAL HEAT
0002: Inlet Temperature 600.F
0003: Outlet Temperature 200.F
0004: Run Time 3:00
0005: END OF OPERATION

Operation #34 VALVE POSITION LIMIT

0001: VALVE POSITION LIMIT
0002: Max Gas Valve Setting = 3500
0003: END OF OPERATION

Operation #35 HEAT WITH RECIRC.

0001: HEAT WITH RECIRC.
0002: Recirculation On
0003: Inlet Temperature 600.F
0004: Outlet Temperature 190.F
0005: Run Time 13:00
0006: END OF OPERATION

Operation #36 PURGE - NO HEAT

0001: PURGE - NO HEAT
0002: Run Time 5:00
0003: END OF OPERATION

Operation #37 BYPASS LINT FILTER

0001: BYPASS LINT FILTER
0002: Lint Bypass
0003: Aux Output #1 2:00
0004: Run Time 3:00
0005: END OF OPERATION

Operation #38 COOLDOWN

0001: COOLDOWN
0002: Cooldown When Temp > 135.F
0003: Run Time 5:00
0004: END OF OPERATION

Operation #39 ROTATE CW ONLY

0001: ROTATE CW ONLY
0002: Rotate CW for 999 Seconds
0003: END OF OPERATION

Operation #40 REVERSE 30/30/2

0001: REVERSE 30/30/2
0002: Rotate CW for 30 Seconds
0003: Rotate CCW for 30 Seconds
0004: Dwell Timer 2 Seconds
0005: END OF OPERATION

Operation #41 REVERSE 30/30/4

0001: REVERSE 30/30/4
0002: Rotate CW for 30 Seconds
0003: Rotate CCW for 30 Seconds
0004: Dwell Timer 4 Seconds
0005: END OF OPERATION

Operation #42 REVERSE 50/50/2

0001: REVERSE 50/50/2
0002: Rotate CW for 50 Seconds
0003: Rotate CCW for 50 Seconds
0004: Dwell Timer 2 Seconds
0005: END OF OPERATION

Operation #43 REVERSE 50/50/4

0001: REVERSE 50/50/4
0002: Rotate CW for 50 Seconds
0003: Rotate CCW for 50 Seconds
0004: Dwell Timer 4 Seconds
0005: END OF OPERATION

Operation #44 REVERSE 90/90/2

0001: REVERSE 90/90/2
0002: Rotate CW for 90 Seconds
0003: Rotate CCW for 90 Seconds
0004: Dwell Timer 2 Seconds
0005: END OF OPERATION

Operation #45 REVERSE 90/90/4

0001: REVERSE 90/90/4
0002: Rotate CW for 90 Seconds
0003: Rotate CCW for 90 Seconds
0004: Dwell Timer 4 Seconds
0005: END OF OPERATION

Operation #46 TUMBLE ONLY

0001: TUMBLE ONLY
0002: Tumble Only
0003: Run Time 0:00
0004: END OF OPERATION

Operation #47 LOW TEMP HEAT CYCLE

0001: LOW TEMP HEAT CYCLE
0002: Recirculation On
0003: Inlet Temperature 525.F
0004: Outlet Temperature 170.F
0005: Run Time 18:00
0006: END OF OPERATION

Operation #48 MED TEMP HEAT CYCLE

0001: MED TEMP HEAT CYCLE
0002: Recirculation On
0003: Inlet Temperature 550.F
0004: Outlet Temperature 190.F
0005: Run Time 16:00
0006: END OF OPERATION

Operation #49 HI TEMP HEAT CYCLE

0001: HI TEMP HEAT CYCLE
0002: Recirculation On
0003: Inlet Temperature 600.F
0004: Outlet Temperature 200.F
0005: Run Time 14:00
0006: END OF OPERATION

Operation #50 LIGHT CONDITION

0001: LIGHT CONDITION
0002: Recirculation On
0003: Inlet Temperature 525.F
0004: Outlet Temperature 170.F
0005: Run Time 4:00
0006: END OF OPERATION

Operation #51 MEDIUM CONDITION

0001: MEDIUM CONDITION
0002: Recirculation On
0003: Inlet Temperature 550.F
0004: Outlet Temperature 180.F
0005: Run Time 6:00
0006: END OF OPERATION

Operation #52 HEAVY CONDITION

0001: HEAVY CONDITION
0002: Recirculation On
0003: Inlet Temperature 600.F
0004: Outlet Temperature 190.F
0005: Run Time 8:00
0006: END OF OPERATION

Operation #53 INLET ALGORITHM

0001: INLET ALGORITHM
0002: Recirculation On
0003: Inlet Temperature 600.F
0004: Outlet Temperature 200.F
0005: End Step If Inlet < 375.F for 0:30
0006: Run Time 15:00
0007: END OF OPERATION

Operation #54 OUTLET ALGORITHM #1

0001: OUTLET ALGORITHM #1
0002: Recirculation On
0003: Inlet Temperature 600.F
0004: Outlet Temperature 200.F
0005: End Step If Outlet Rises From 150 to 160.F in 0:25
0006: Run Time 6:00
0007: END OF OPERATION

Operation #55 OUTLET ALGORITHM #2

0001: OUTLET ALGORITHM #2
0002: Inlet Temperature 600.F
0003: Outlet Temperature 200.F
0004: End Step If Outlet Rises From 200 to 200.F in 99:00
0005: Run Time 14:00
0006: END OF OPERATION

Operation #56 HUMIDITY ALGORITHM 1

0001: HUMIDITY ALGORITHM 1
0002: Recirculation On
0003: Inlet Temperature 600.F
0004: Outlet Temperature 200.F
0005: End Step If Humidity #1 < 10.0 for 0:30
0006: Run Time 14:00
0007: END OF OPERATION

Operation #57 HUMIDITY ALGORITHM 2

0001: HUMIDITY ALGORITHM 2
0002: Recirculation On
0003: Inlet Temperature 600.F
0004: Outlet Temperature 200.F
0005: End Step If Humidity #2 < 10.0 for 0:30
0006: Run Time 14:00
0007: END OF OPERATION

Operation #58 ONE CAKE ALGORITHM

0001: ONE CAKE ALGORITHM
0002: Recirculation On
0003: Inlet Temperature 600.F
0004: Outlet Temperature 200.F
0005: Run Time 10:00
0006: END OF OPERATION

Operation #59 UNLOAD MANUALLY

0001: UNLOAD MANUALLY
0002: Auto Discharge Front
0003: Run Time 0:05
0004: END OF OPERATION

Operation #60 UNLOAD SMALL PIECES

0001: UNLOAD SMALL PIECES
0002: Auto Discharge Front
0003: Run Time 0:05
0004: Rotate CW for 15 Seconds
0005: Rotate CCW for 15 Seconds
0006: Dwell Timer 5 Seconds
0007: Run Time 1:30
0008: END OF OPERATION

Operation #61 UNLOAD MEDIUM PIECES

0001: UNLOAD MEDIUM PIECES
0002: Auto Discharge Front
0003: Run Time 0:05
0004: Rotate CW for 10 Seconds
0005: Rotate CCW for 10 Seconds
0006: Dwell Timer 5 Seconds
0007: Run Time 1:10
0008: END OF OPERATION

Operation #62 UNLOAD LARGE PIECES

0001: UNLOAD LARGE PIECES
0002: Auto Discharge Front
0003: Run Time 0:05
0004: Rotate CW for 2 Seconds
0005: Rotate CCW for 2 Seconds
0006: Dwell Timer 4 Seconds
0007: Run Time 1:00
0008: END OF OPERATION

Operation #63 RUNNING PROMPT

0001: RUNNING PROMPT
0002: Prompt: Check Load!!
0003: Signal Until Operator Cancels
0004: Run Time 0:00
0005: END OF OPERATION

Operation #64 STOPPED PROMPT

0001: STOPPED PROMPT
0002: Tumble Only
0003: Dwell Timer 999 Seconds
0004: Prompt: Is Load Dry?
0005: Signal Until Operator Cancels
0006: Run Time 0:00
0007: END OF OPERATION

Formula #100 Sheets

0001: Sheets
0002: ROTATE CW ONLY
0003: Rotate CW for 999 Seconds
0004: INITIAL HEAT
0005: Inlet Temperature 650.F
0006: Outlet Temperature 190.F
0007: Run Time 8:00
0008: LOW TEMP HEAT CYCLE
0009: Recirculation On
0010: Inlet Temperature 500.F
0011: Outlet Temperature 185.F
0012: Run Time 3:00
0013: REVERSE 30/30/4
0014: Rotate CW for 30 Seconds
0015: Rotate CCW for 30 Seconds
0016: Dwell Timer 4 Seconds
0017: COOLDOWN
0018: Cooldown When Temp > 135.F
0019: Run Time 5:00
0020: END OF FORMULA

Formula #101 Uniforms & Sheet

0001: Uniforms & Sheet
0002: VALVE POSITION LIMIT
0003: Max Gas Valve Setting = 3500
0004: INITIAL HEAT
0005: Inlet Temperature 525.F
0006: Outlet Temperature 170.F
0007: Run Time 3:00
0008: LOW TEMP HEAT CYCLE
0009: Recirculation On
0010: Inlet Temperature 525.F
0011: Outlet Temperature 170.F
0012: Run Time 15:00
0013: COOLDOWN
0014: Cooldown When Temp > 130.F
0015: Run Time 5:00
0016: END OF FORMULA

Formula #102 White Towels

0001: White Towels
0002: INITIAL HEAT
0003: Inlet Temperature 550.F
0004: Outlet Temperature 190.F
0005: Run Time 3:00
0006: MED TEMP HEAT CYCLE
0007: Recirculation On
0008: Inlet Temperature 550.F
0009: Outlet Temperature 190.F
0010: Run Time 13:00
0011: COOLDOWN
0012: Cooldown When Temp > 135.F
0013: Run Time 5:00
0014: END OF FORMULA

Formula #103 Color Towels

0001: Color Towels
0002: INITIAL HEAT
0003: Inlet Temperature 600.F
0004: Outlet Temperature 200.F
0005: Run Time 3:00
0006: HI TEMP HEAT CYCLE
0007: Recirculation On
0008: Inlet Temperature 600.F
0009: Outlet Temperature 200.F
0010: Run Time 11:00
0011: COOLDOWN
0012: Cooldown When Temp > 135.F
0013: Run Time 5:00
0014: END OF FORMULA

Formula #104 Delicates

0001: Delicates
0002: INITIAL HEAT
0003: Inlet Temperature 550.F
0004: Outlet Temperature 190.F
0005: Run Time 3:00
0006: MED TEMP HEAT CYCLE
0007: Recirculation On
0008: Inlet Temperature 550.F
0009: Outlet Temperature 190.F
0010: Run Time 5:00
0011: INLET ALGORITHM
0012: Recirculation On
0013: Inlet Temperature 550.F
0014: Outlet Temperature 190.F
0015: End Step If Inlet < 375.F for 2:00
0016: Run Time 8:00
0017: COOLDOWN
0018: Cooldown When Temp > 135.F
0019: Run Time 5:00
0020: END OF FORMULA

Formula #105 Chef Coats

0001: Chef Coats
0002: OUTLET ALGORITHM #1
0003: Recirculation On
0004: Inlet Temperature 600.F
0005: Outlet Temperature 200.F
0006: End Step If Outlet Rises From 150 to 160.F in 0:25
0007: Run Time 6:00
0008: MED TEMP HEAT CYCLE
0009: Recirculation On
0010: Inlet Temperature 550.F
0011: Outlet Temperature 190.F
0012: Run Time 8:00
0013: COOLDOWN
0014: Cooldown When Temp > 135.F
0015: Run Time 5:00
0016: END OF FORMULA

Formula #106 Kitchen Rags

0001: Kitchen Rags
0002: INITIAL HEAT
0003: Inlet Temperature 600.F
0004: Outlet Temperature 200.F
0005: Run Time 3:00
0006: HI TEMP HEAT CYCLE
0007: Recirculation On
0008: Inlet Temperature 600.F
0009: Outlet Temperature 200.F
0010: Run Time 5:00
0011: HUMIDITY ALGORITHM 1
0012: Recirculation On
0013: Inlet Temperature 600.F
0014: Outlet Temperature 200.F
0015: End Step If Humidity #1 < 10.0 for 0:30
0016: Run Time 14:00
0017: COOLDOWN
0018: Cooldown When Temp > 135.F
0019: Run Time 5:00
0020: END OF FORMULA

Formula #107 Mops

0001: Mops
0002: MED TEMP HEAT CYCLE
0003: Recirculation On
0004: Inlet Temperature 550.F
0005: Outlet Temperature 190.F
0006: Run Time 6:00
0007: COOLDOWN
0008: Cooldown When Temp > 135.F
0009: Run Time 5:00
0010: END OF FORMULA

Formula #108 White Table Linen

0001: White Table Linen
0002: MED TEMP HEAT CYCLE
0003: Recirculation On
0004: Inlet Temperature 550.F
0005: Outlet Temperature 190.F
0006: Run Time 10:00
0007: COOLDOWN
0008: Cooldown When Temp > 135.F
0009: Run Time 5:00
0010: END OF FORMULA

Formula #109 Color Table Linen

0001: Color Table Linen
0002: INITIAL HEAT
0003: Inlet Temperature 550.F
0004: Outlet Temperature 190.F
0005: Run Time 3:00
0006: MED TEMP HEAT CYCLE
0007: Recirculation On
0008: Inlet Temperature 550.F
0009: Outlet Temperature 190.F
0010: Run Time 11:00
0011: COOLDOWN
0012: Cooldown When Temp > 135.F
0013: Run Time 5:00
0014: END OF FORMULA

Formula #110 WhitePoly. Linen

0001: WhitePoly. Linen
0002: LIGHT CONDITION
0003: Recirculation On
0004: Inlet Temperature 550.F
0005: Outlet Temperature 180.F
0006: Run Time 5:00
0007: COOLDOWN
0008: Cooldown When Temp > 135.F
0009: Run Time 5:00
0010: END OF FORMULA

Formula #111 Pool/Spa Towels

0001: Pool/Spa Towels
0002: INITIAL HEAT
0003: Inlet Temperature 600.F
0004: Outlet Temperature 200.F
0005: Run Time 3:00
0006: HI TEMP HEAT CYCLE
0007: Recirculation On
0008: Inlet Temperature 600.F
0009: Outlet Temperature 200.F
0010: Run Time 14:00
0011: COOLDOWN
0012: Cooldown When Temp > 135.F
0013: Run Time 5:00
0014: END OF FORMULA

Formula #112 ColorPoly. Linen

0001: ColorPoly. Linen
0002: ROTATE CW ONLY
0003: Rotate CW for 999 Seconds
0004: INITIAL HEAT
0005: Inlet Temperature 600.F
0006: Outlet Temperature 200.F
0007: Run Time 3:00
0008: HI TEMP HEAT CYCLE
0009: Recirculation On
0010: Inlet Temperature 600.F
0011: Outlet Temperature 200.F
0012: Run Time 5:00
0013: INLET ALGORITHM
0014: Recirculation On
0015: Inlet Temperature 600.F
0016: Outlet Temperature 200.F
0017: End Step If Inlet < 375.F for 0:30
0018: Run Time 7:00
0019: COOLDOWN
0020: Cooldown When Temp > 135.F
0021: Run Time 5:00
0022: END OF FORMULA

Formula #113 Personals

0001: Personals
0002: ROTATE CW ONLY
0003: Rotate CW for 999 Seconds
0004: INITIAL HEAT
0005: Inlet Temperature 600.F
0006: Outlet Temperature 200.F
0007: Run Time 3:00
0008: HI TEMP HEAT CYCLE
0009: Recirculation On
0010: Inlet Temperature 600.F
0011: Outlet Temperature 200.F
0012: Run Time 5:00
0013: INLET ALGORITHM
0014: Recirculation On
0015: Inlet Temperature 600.F
0016: Outlet Temperature 200.F
0017: End Step If Inlet < 375.F for 0:30
0018: Run Time 8:00
0019: COOLDOWN
0020: Cooldown When Temp > 135.F
0021: Run Time 5:00
0022: END OF FORMULA

Formula #114 Diapers

0001: Diapers
0002: VALVE POSITION LIMIT
0003: Max Gas Valve Setting = 3500
0004: ROTATE CW ONLY
0005: Rotate CW for 999 Seconds
0006: PURGE - NO HEAT
0007: Run Time 5:00
0008: INITIAL HEAT
0009: Inlet Temperature 525.F
0010: Outlet Temperature 180.F
0011: Run Time 3:00
0012: MED TEMP HEAT CYCLE
0013: Recirculation On
0014: Inlet Temperature 525.F
0015: Outlet Temperature 180.F
0016: Run Time 5:00
0017: INLET ALGORITHM
0018: Recirculation On
0019: Inlet Temperature 525.F
0020: Outlet Temperature 180.F
0021: End Step If Inlet < 375.F for 0:30
0022: Run Time 7:00
0023: COOLDOWN
0024: Cooldown When Temp > 115.F
0025: Run Time 7:00
0026: END OF FORMULA

Formula #115 Polyester Pads

0001: Polyester Pads
0002: VALVE POSITION LIMIT
0003: Max Gas Valve Setting = 3500
0004: ROTATE CW ONLY
0005: Rotate CW for 999 Seconds
0006: INITIAL HEAT
0007: Inlet Temperature 525.F
0008: Outlet Temperature 170.F
0009: Run Time 3:00
0010: LOW TEMP HEAT CYCLE
0011: Recirculation On
0012: Inlet Temperature 525.F
0013: Outlet Temperature 170.F
0014: Run Time 5:00
0015: INLET ALGORITHM
0016: Recirculation On
0017: Inlet Temperature 525.F
0018: Outlet Temperature 170.F
0019: End Step If Inlet < 375.F for 0:30
0020: Run Time 7:00
0021: COOLDOWN
0022: Cooldown When Temp > 115.F
0023: Run Time 7:00
0024: END OF FORMULA

Formula #116 Housekeeping Rag

0001: Housekeeping Rag
0002: VALVE POSITION LIMIT
0003: Max Gas Valve Setting = 3500
0004: ROTATE CW ONLY
0005: Rotate CW for 999 Seconds
0006: INITIAL HEAT
0007: Inlet Temperature 550.F
0008: Outlet Temperature 180.F
0009: Run Time 3:00
0010: LOW TEMP HEAT CYCLE
0011: Recirculation On
0012: Inlet Temperature 550.F
0013: Outlet Temperature 180.F
0014: Run Time 5:00
0015: INLET ALGORITHM
0016: Recirculation On
0017: Inlet Temperature 550.F
0018: Outlet Temperature 180.F
0019: End Step If Inlet < 290.F for 1:30
0020: Run Time 9:00
0021: COOLDOWN
0022: Cooldown When Temp > 125.F
0023: Run Time 6:00
0024: END OF FORMULA

Formula #117 AIDS/Disease

0001: AIDS/Disease
0002: HEAVY CONDITION
0003: Recirculation On
0004: Inlet Temperature 600.F
0005: Outlet Temperature 200.F
0006: Run Time 10:00
0007: COOLDOWN
0008: Cooldown When Temp > 135.F
0009: Run Time 5:00
0010: END OF FORMULA

Formula #118 Shirts

0001: Shirts
0002: ROTATE CW ONLY
0003: Rotate CW for 999 Seconds
0004: HEAVY CONDITION
0005: Recirculation On
0006: Inlet Temperature 600.F
0007: Outlet Temperature 200.F
0008: Run Time 8:00
0009: COOLDOWN
0010: Cooldown When Temp > 135.F
0011: Run Time 5:00
0012: END OF FORMULA

Formula #119 Lt. Starch/Extr.

0001: Lt. Starch/Extr.
0002: VALVE POSITION LIMIT
0003: Max Gas Valve Setting = 3500
0004: MEDIUM CONDITION
0005: Recirculation On
0006: Inlet Temperature 550.F
0007: Outlet Temperature 180.F
0008: Run Time 8:00
0009: COOLDOWN
0010: Cooldown When Temp > 115.F
0011: Run Time 6:00
0012: END OF FORMULA

Formula #120 Extra Rinse Extr

0001: Extra Rinse Extr
0002: VALVE POSITION LIMIT
0003: Max Gas Valve Setting = 3500
0004: HEAVY CONDITION
0005: Recirculation On
0006: Inlet Temperature 550.F
0007: Outlet Temperature 180.F
0008: Run Time 11:00
0009: COOLDOWN
0010: Cooldown When Temp > 115.F
0011: Run Time 7:00
0012: END OF FORMULA

Formula #121 General Wash

0001: General Wash
0002: VALVE POSITION LIMIT
0003: Max Gas Valve Setting = 3500
0004: REVERSE 30/30/4
0005: Rotate CW for 30 Seconds
0006: Rotate CCW for 30 Seconds
0007: Dwell Timer 4 Seconds
0008: INITIAL HEAT
0009: Inlet Temperature 550.F
0010: Outlet Temperature 180.F
0011: Run Time 3:00
0012: LOW TEMP HEAT CYCLE
0013: Recirculation On
0014: Inlet Temperature 550.F
0015: Outlet Temperature 180.F
0016: Run Time 5:00
0017: INLET ALGORITHM
0018: Recirculation On
0019: Inlet Temperature 550.F
0020: Outlet Temperature 180.F
0021: End Step If Inlet < 290.F for 0:30
0022: Run Time 8:00
0023: COOLDOWN
0024: Cooldown When Temp > 135.F
0025: Run Time 5:00
0026: END OF FORMULA

Formula #122 Pillow Cases

0001: Pillow Cases
0002: INITIAL HEAT
0003: Inlet Temperature 600.F
0004: Outlet Temperature 200.F
0005: Run Time 3:00
0006: HI TEMP HEAT CYCLE
0007: Recirculation On
0008: Inlet Temperature 600.F
0009: Outlet Temperature 200.F
0010: Run Time 5:00
0011: INLET ALGORITHM
0012: Recirculation On
0013: Inlet Temperature 600.F
0014: Outlet Temperature 200.F
0015: End Step If Inlet < 310.F for 1:00
0016: Run Time 12:00
0017: COOLDOWN
0018: Cooldown When Temp > 135.F
0019: Run Time 5:00
0020: END OF FORMULA

Formula #123 Extra Heavy Soil

0001: Extra Heavy Soil
0002: INITIAL HEAT
0003: Inlet Temperature 600.F
0004: Outlet Temperature 200.F
0005: Run Time 3:00
0006: HI TEMP HEAT CYCLE
0007: Recirculation On
0008: Inlet Temperature 600.F
0009: Outlet Temperature 200.F
0010: Run Time 6:00
0011: INLET ALGORITHM
0012: Recirculation On
0013: Inlet Temperature 600.F
0014: Outlet Temperature 200.F
0015: End Step If Inlet < 300.F for 1:00
0016: Run Time 12:00
0017: COOLDOWN
0018: Cooldown When Temp > 135.F
0019: Run Time 5:00
0020: END OF FORMULA

Formula #124 Wool Blankets

0001: Wool Blankets
0002: INITIAL HEAT
0003: Inlet Temperature 600.F
0004: Outlet Temperature 200.F
0005: Run Time 3:00
0006: HI TEMP HEAT CYCLE
0007: Recirculation On
0008: Inlet Temperature 600.F
0009: Outlet Temperature 200.F
0010: Run Time 7:00
0011: INLET ALGORITHM
0012: Recirculation On
0013: Inlet Temperature 600.F
0014: Outlet Temperature 200.F
0015: End Step If Inlet < 290.F for 1:00
0016: Run Time 12:00
0017: COOLDOWN
0018: Cooldown When Temp > 135.F
0019: Run Time 5:00
0020: END OF FORMULA

Formula #125 Stain Treatment

0001: Stain Treatment
0002: ROTATE CW ONLY
0003: Rotate CW for 999 Seconds
0004: RUNNING PROMPT
0005: Prompt: Check Load!!
0006: Signal Until Operator Cancels
0007: Run Time 0:30
0008: Run Time 0:05
0009: STOPPED PROMPT
0010: Tumble Only
0011: Dwell Timer 999 Seconds
0012: Prompt: Is Load Dry?
0013: Signal Until Operator Cancels
0014: Run Time 0:00
0015: ROTATE CW ONLY
0016: Rotate CW for 999 Seconds
0017: TUMBLE ONLY
0018: Tumble Only
0019: Run Time 0:30
0020: END OF FORMULA

Formula #126 Cotton Blankets

0001: Cotton Blankets
0002: VALVE POSITION LIMIT
0003: Max Gas Valve Setting = 2000
0004: ROTATE CW ONLY
0005: Rotate CW for 999 Seconds
0006: LOW TEMP HEAT CYCLE
0007: Recirculation On
0008: Inlet Temperature 425.F
0009: Outlet Temperature 160.F
0010: Run Time 12:00
0011: COOLDOWN
0012: Cooldown When Temp > 110.F
0013: Run Time 5:00
0014: END OF FORMULA

Formula #127 Uniforms

0001: Uniforms
0002: TUMBLE ONLY
0003: Tumble Only
0004: UNLOAD MEDIUM PIECES
0005: Auto Discharge Front
0006: Run Time 0:05
0007: Rotate CW for 10 Seconds
0008: Rotate CCW for 10 Seconds
0009: Dwell Timer 5 Seconds
0010: Run Time 1:10
0011: END OF FORMULA

Formula #128 Test Formula

0001: Test Formula
0002: ***** Label 1 *****
0003: ROTATE CW ONLY
0004: Rotate CW for 999 Seconds
0005: LOW TEMP HEAT CYCLE
0006: Recirculation On
0007: Inlet Temperature 500.F
0008: Outlet Temperature 150.F
0009: Run Time 2:00
0010: COOLDOWN
0011: Cooldown When Temp > 150.F
0012: Run Time 2:00
0013: STOPPED PROMPT
0014: Tumble Only
0015: Dwell Timer 999 Seconds
0016: Prompt: Is Load Dry?
0017: Prompt: Call Supervisor!
0018: Signal [Yes] = Label 2 [No] = Label 1
0019: Run Time 0:00
0020: ***** Label 2 *****
0021: ROTATE CW ONLY
0022: Rotate CW for 999 Seconds
0023: COOLDOWN
0024: Cooldown When Temp > 125.F
0025: Run Time 2:00
0026: UNLOAD MANUALLY
0027: Auto Discharge Front
0028: Run Time 0:05
0029: END OF FORMULA

Notes:

SOFTROL

Software & Control for Automation

4867 N. MAIN ST. - ACWORTH, GA 30101

PH: (770)974-2700

FAX:(770)974-0435

CHALLENGE
PACESETTER DRYER
TWO DOORS
10 & 20 DEG. FRONT TILT
10 DEG. REAR TILT
LINT SYSTEM

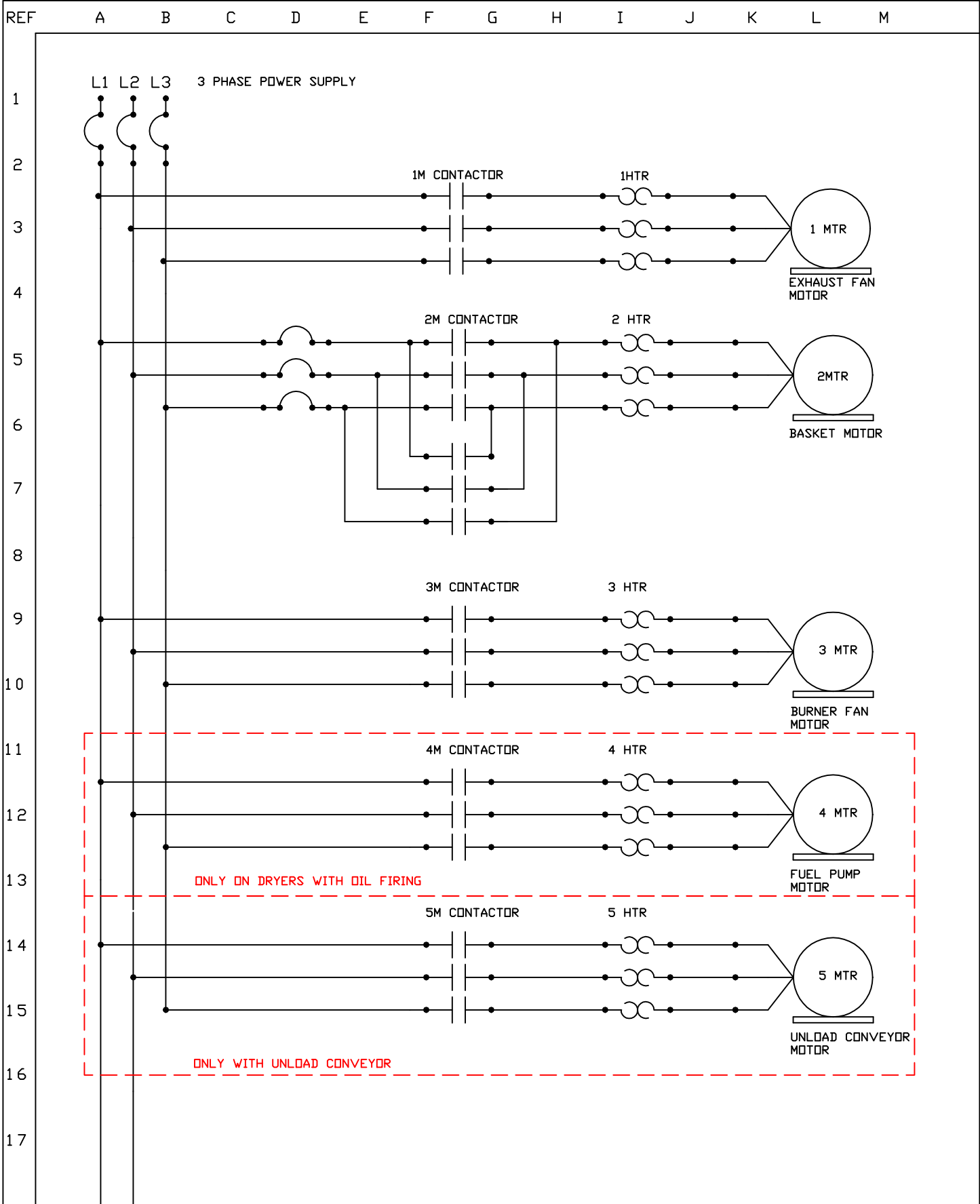

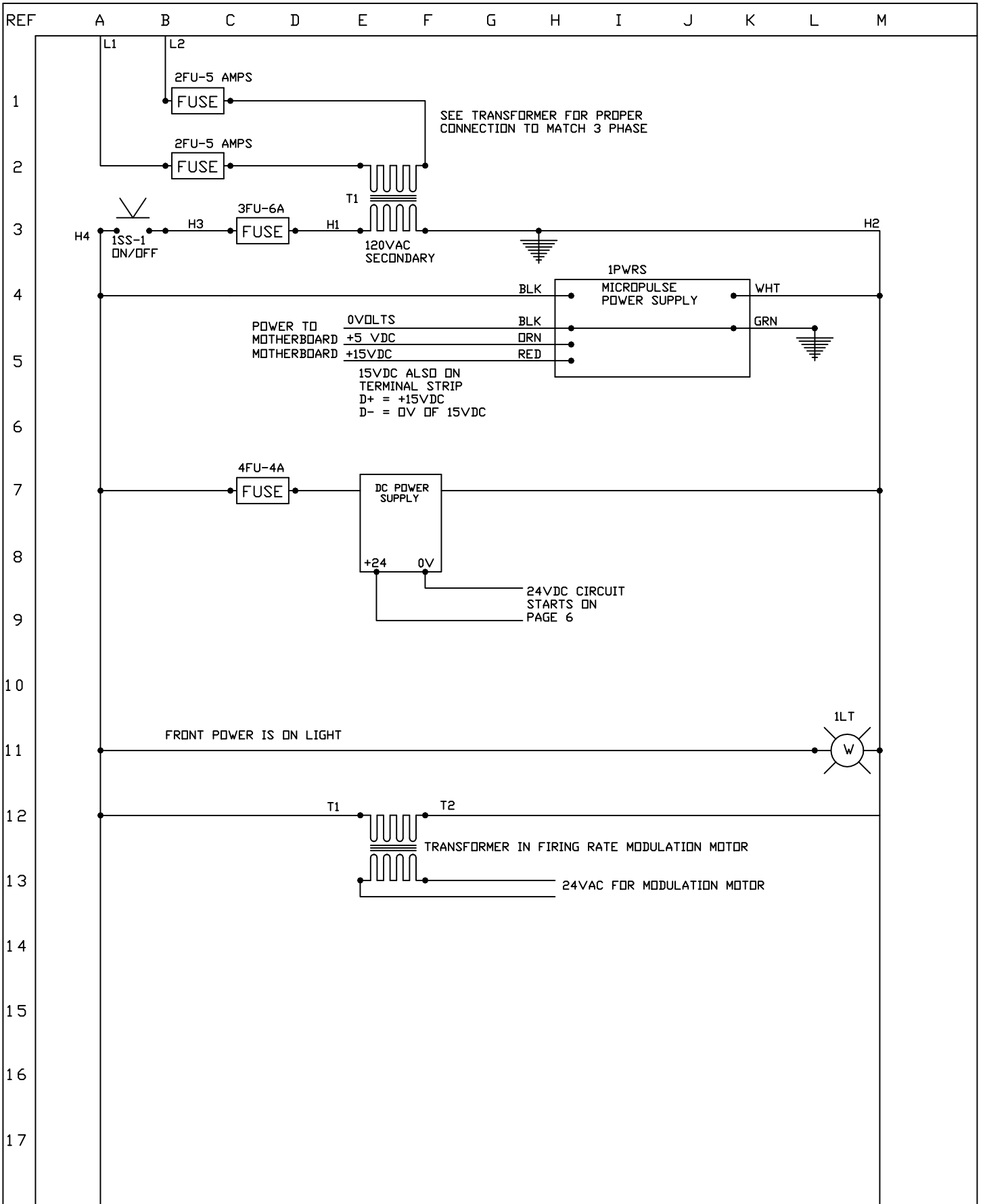

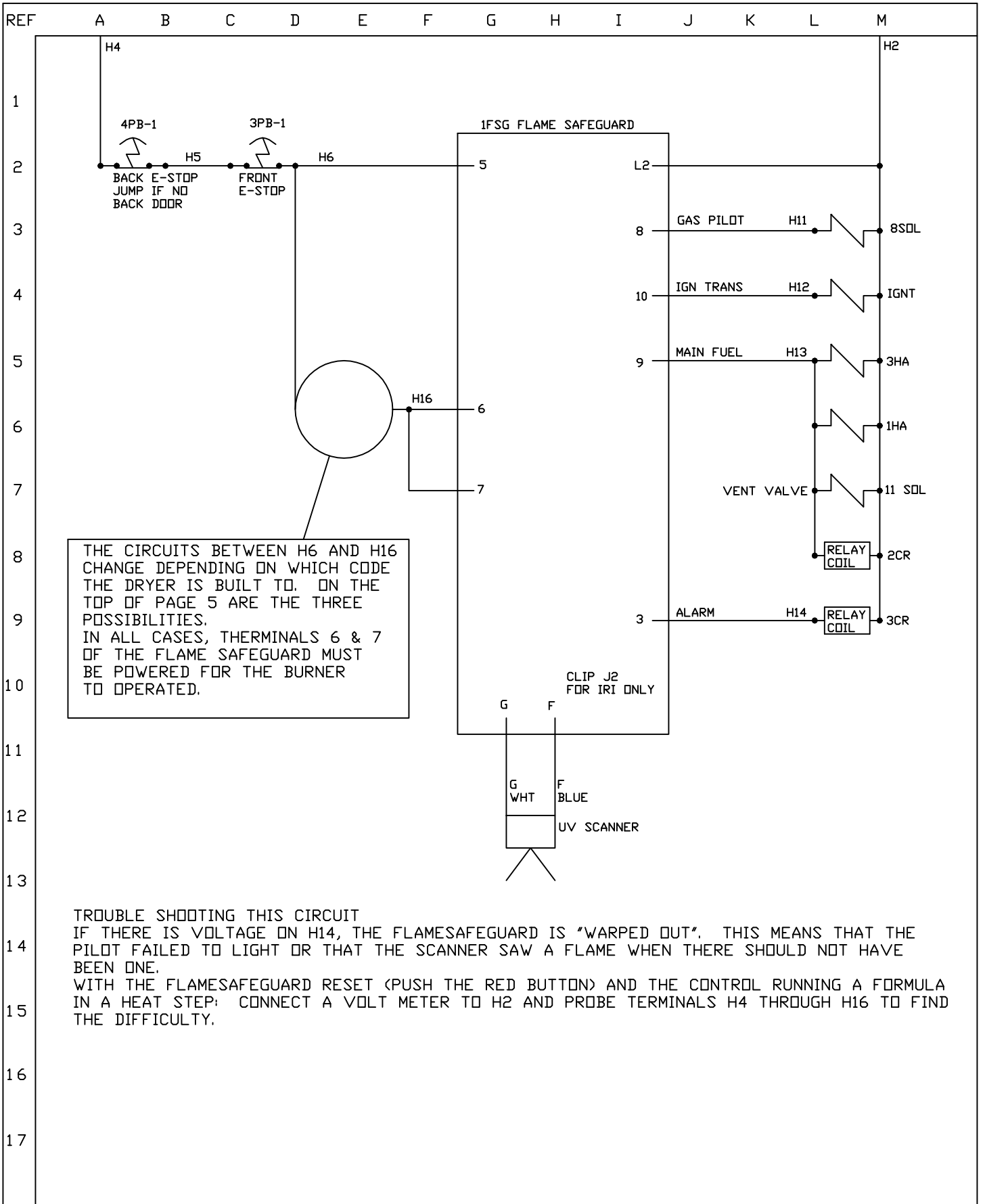

CHOOSE WHICH CIRCUIT APPLIES. CONNECTIONS ARE ON PAGE 3 BETWEEN H6 AND H16

THIS CIRCUIT IS FOR NON-IRI/CSA

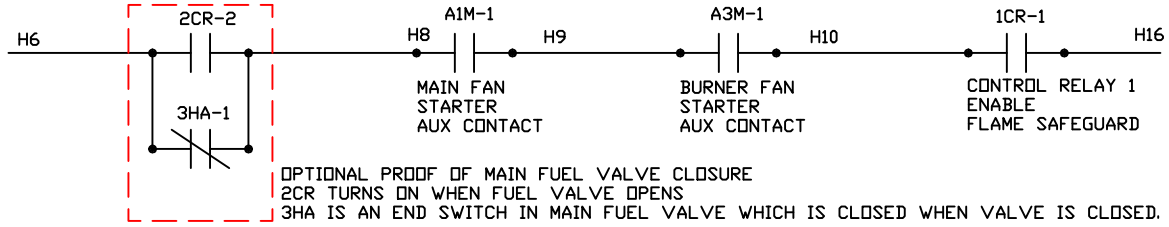

THIS CIRCUIT IS FOR IRI/CSA

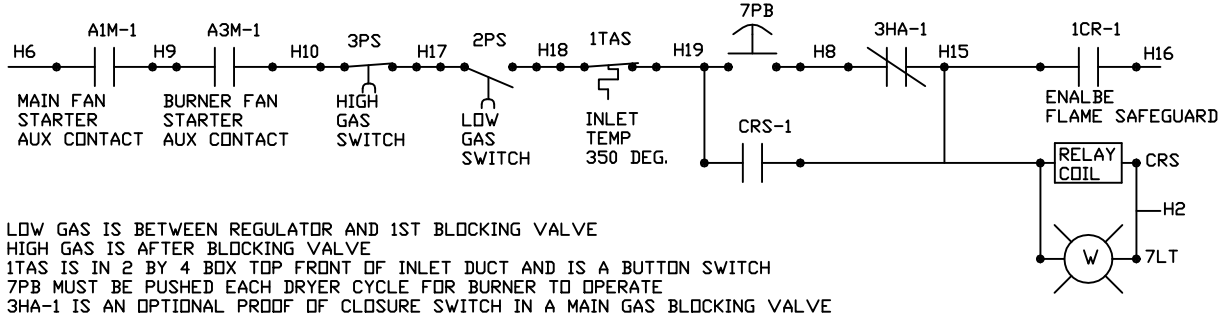

THIS CIRCUIT IS FOR IRI/CSA WITHIN AN AUTOMATED SYSTEM

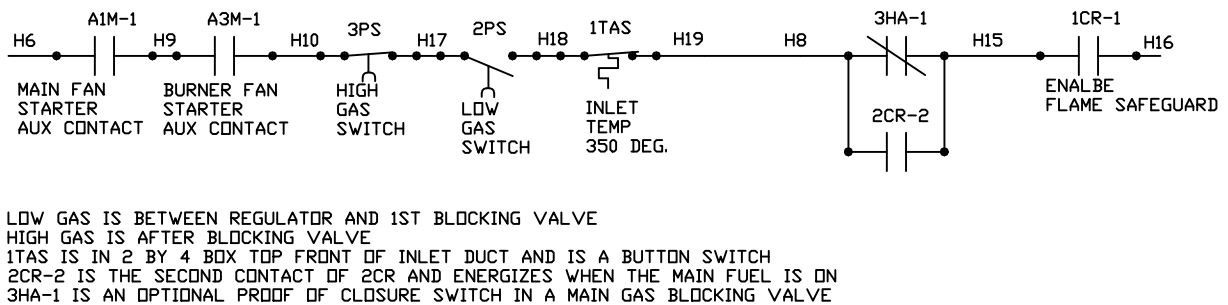

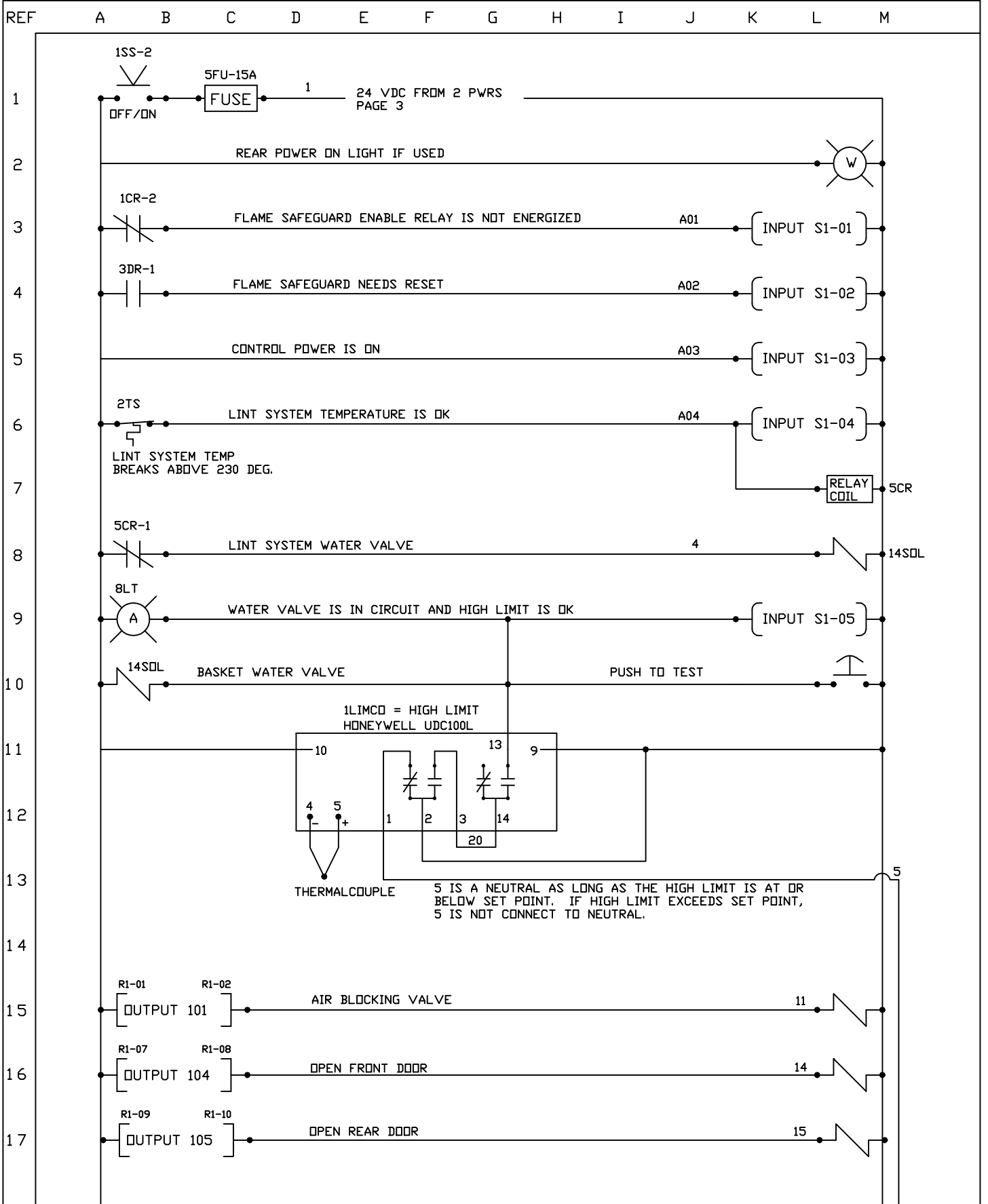

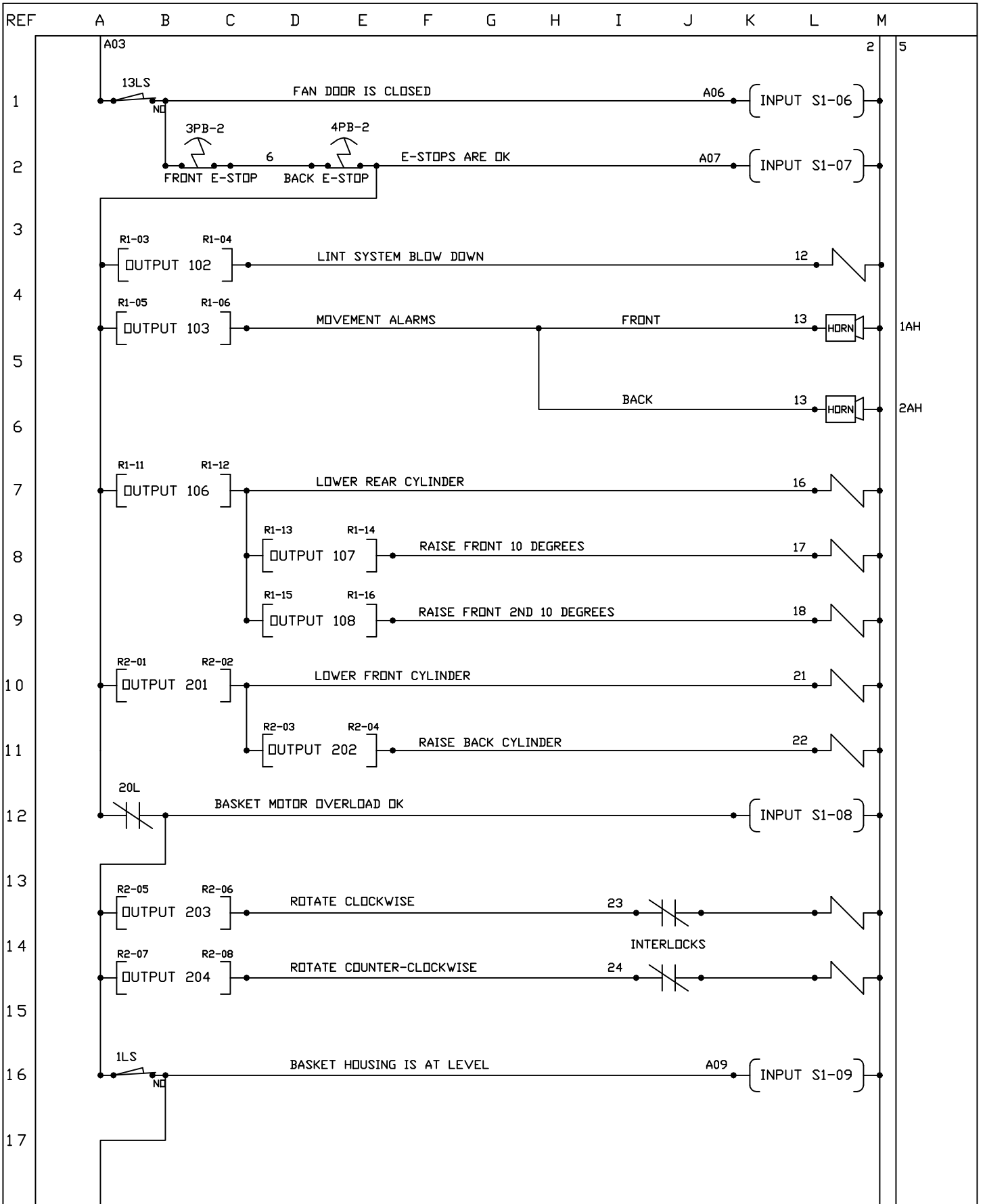

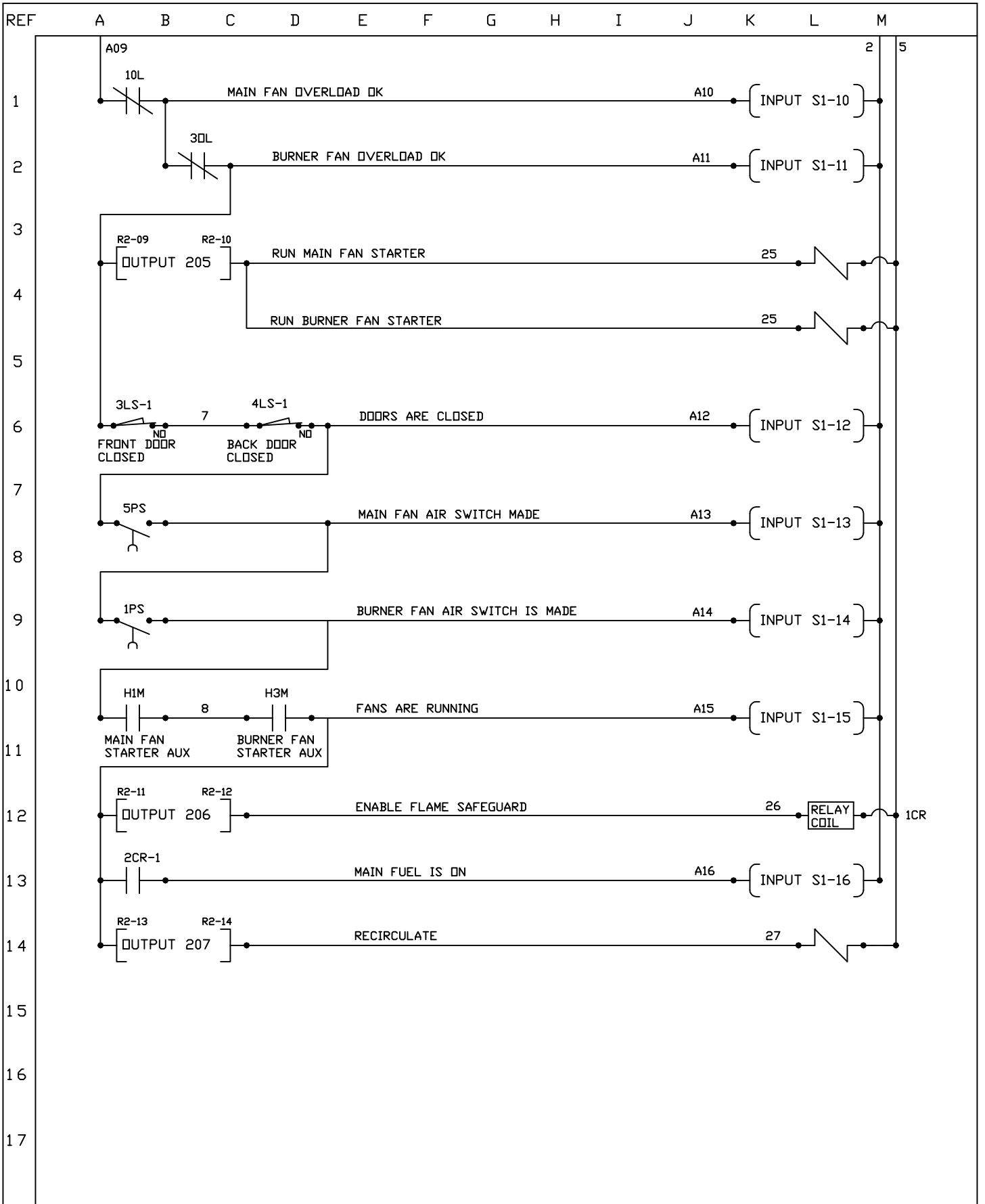

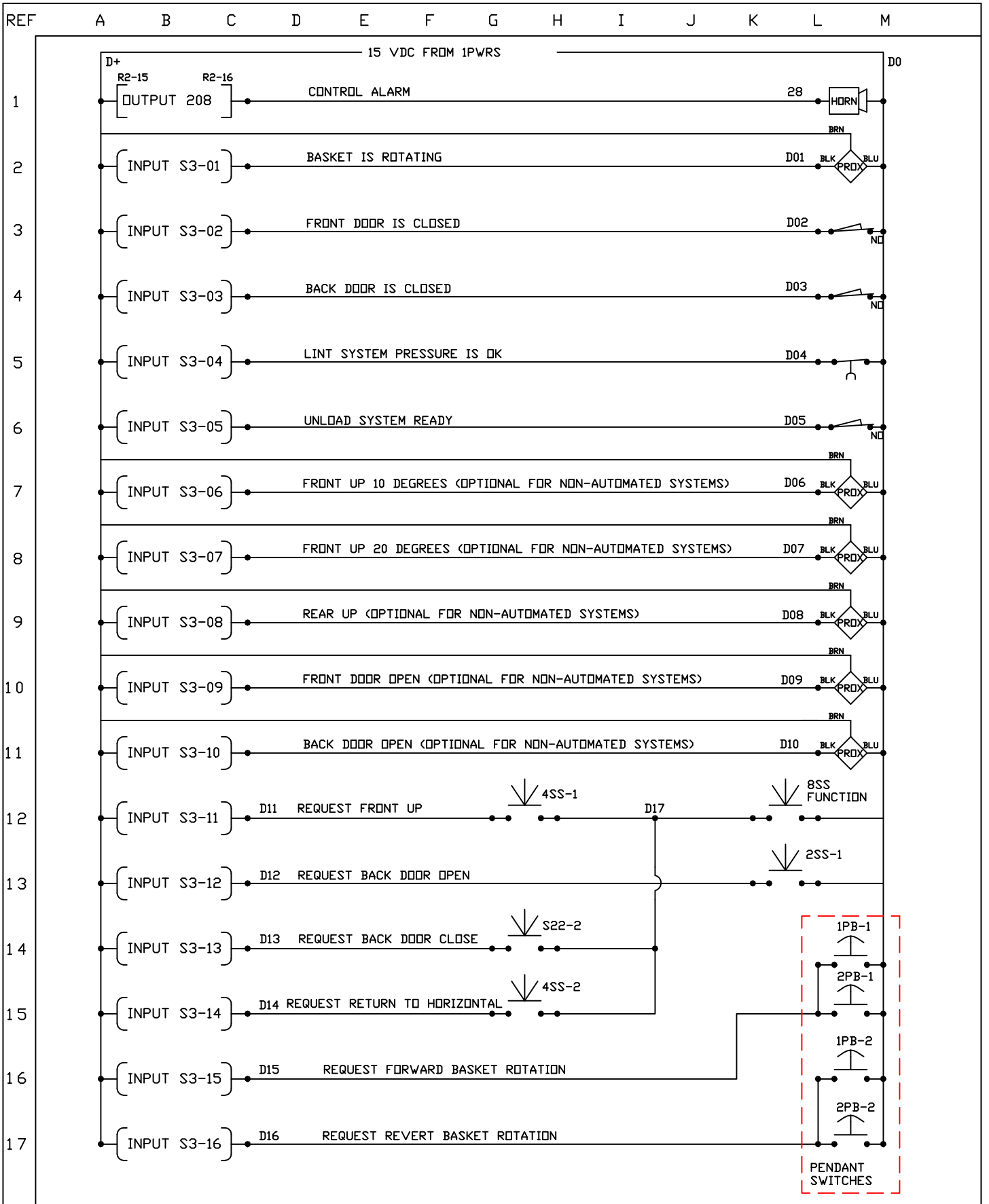

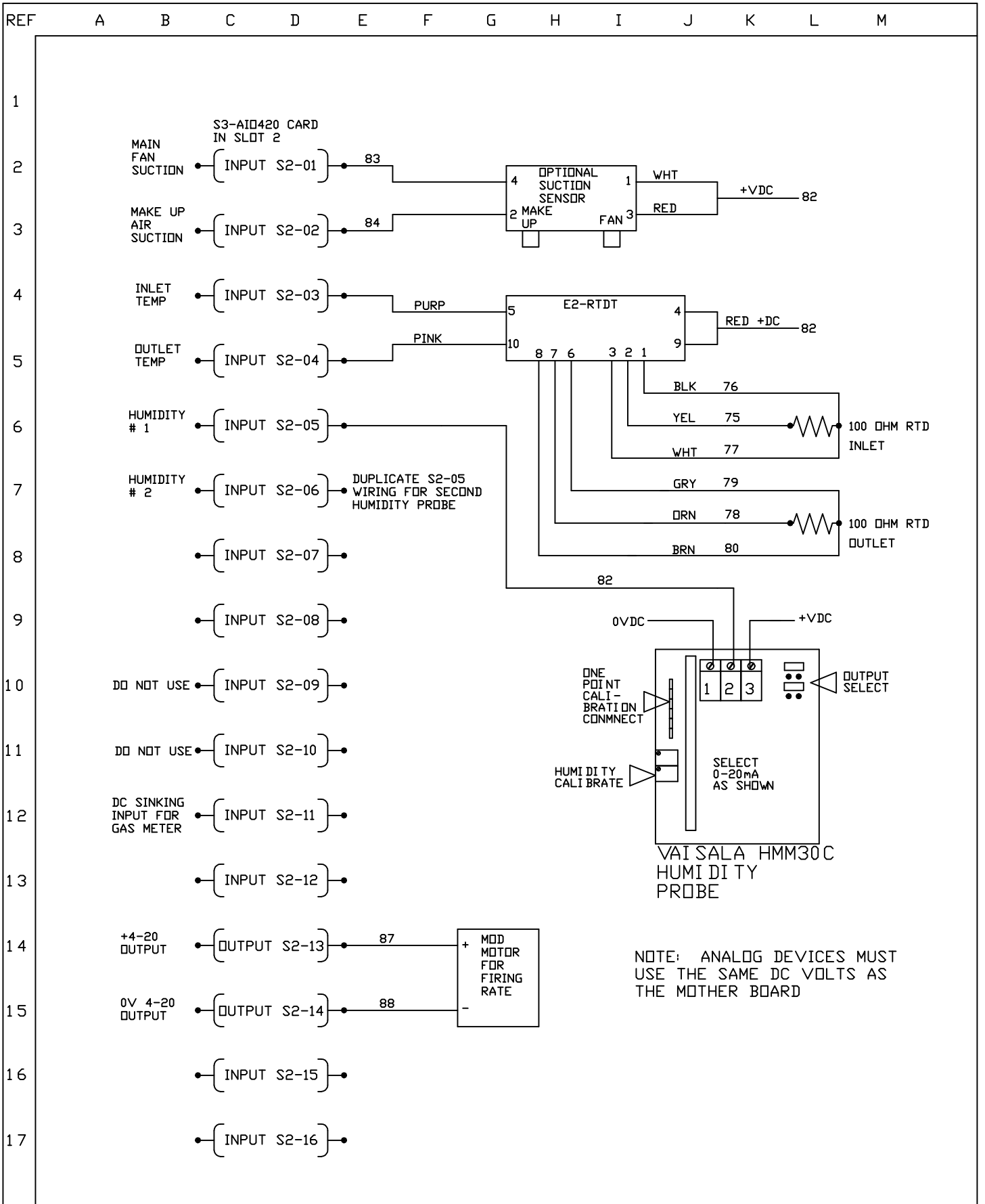

1
2
3
4
5
6
7
8
9
10
11
12
13
14
15
16
17

NOTES:

DRYER GROUND LUG MUST BE CONNECTED TO AN EARTH GROUND USING 8 AWG WIRE WITH A MAXIMUM RESISTANCE OF 1 OHM.

WIRE COLORS

- HIGH VOLTAGE AC = BLACK
- 115VAC = RED
- AC COMMON = GRAY
- DC = BLUE
- GROUND = GREEN\YELLOW

HIGH GAS PRESSURE SWITCH 3PS IF USED IS SET:

- CP-200 = 4.3" WC
- CP-400 = 7.5" WC
- CP-600 = 7.5" WC

LOW GAS PRESSURE SWITCH 2PS IF USED IS SET:

- CP-200 = 2.0" WC
- CP-400 = 4.5" WC
- CP-600 = 4.5" WC

COILS OF OUTPUT DEVICES ARE TO BE EQUIPPED WITH TRANSORBS.

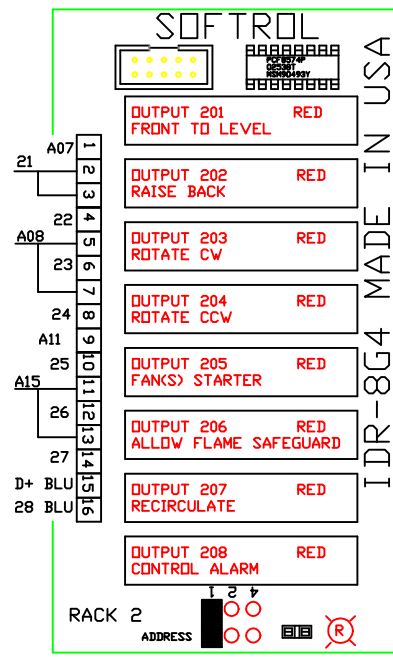
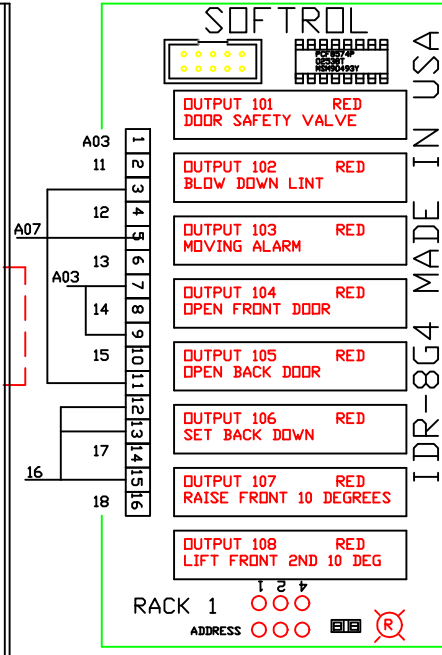
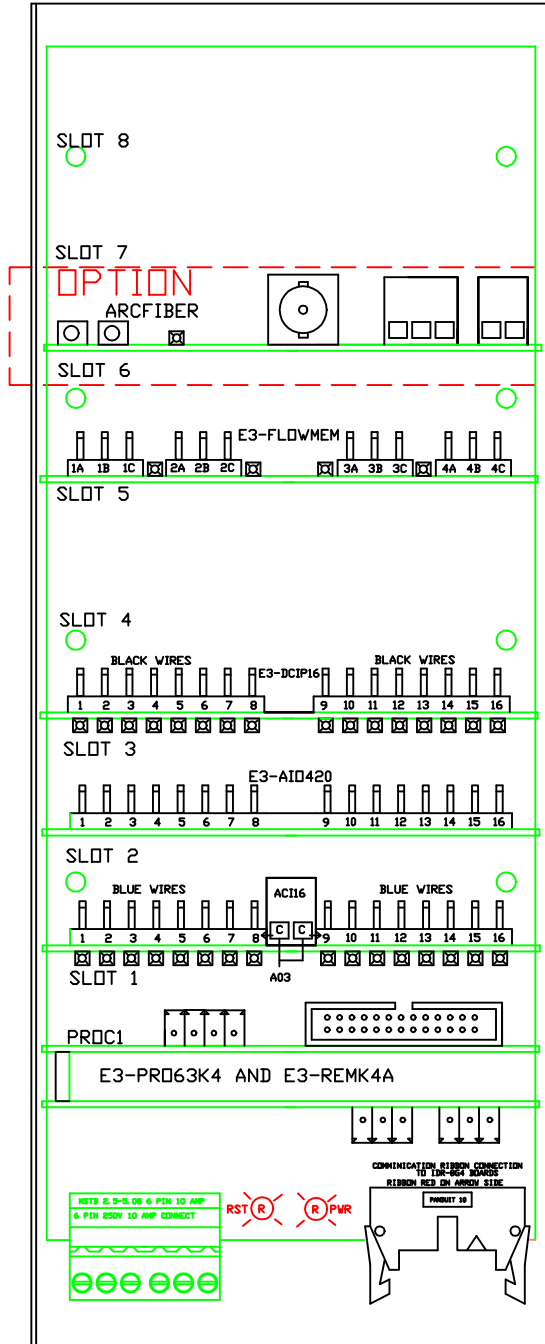

I DR-8G4 MADE IN USA

I DR-8G4 MADE IN USA

SOFTROL

Software & Control for Automation

MICROPULSE **Dryer**

Please visit us on the World Wide Web at www.Softrol.com.

Softrol MicroPulse Dryer Manual

Entire Contents © 2000 - 2001 Softrol System, Inc.

1st Edition 12/21/00

Revised 02/23/01- Updated for new K4 processor.

Revised 11/20/01- New Layout

Revised 12/17/01- Updated Hardware Overview AIO-420 error.

Revised 06/12/02- Added error fault lists.

Revised 06/18/02- Correcting the Hardware Overview Slot error.

Revised 09/24/02- Correcting errors in chapters 4,6, and 12.

Revised 10/09/06- Added Gas Meter Type 1 and Type 2 to Setups Defined

No portion of this manual may be duplicated in any manner without expressed written consent of Softrol Systems, Inc.

1100 Northpoint Parkway

Acworth, GA 30102

770.974.2700

www.softrol.com